



EGT FOR ROTAX ENGINES 503. Diameter 52mm. °C IM-758

Preface

The IM-758 instruments have been designed especially to measure the Exhaust Gas Temperature in Rotax® engines 503.

The IM-758 is available in 52 mm size.

Thanks to embedded operational amplifiers, this instrument has a high accuracy, but needs a power supply of 12V or 24V.

General Information

ATTENTION : The IM-758 has not undergone any safety or durability examination to Civil Aviation standards but does incorporate the latest technical development and has been thoroughly tested. Despite the EGT meter being a precision instrument, false indication or misinterpretation of data could occur. By utilizing this instrument the user acknowledges the possible danger and responsibility for all risks.

State of receipt

- Instruments packed in a plastic bag
- 4 attachment screws
- 3 Loose screws



Technical data

Case:	Plastic
Weight:	220g
Suitable for:	Type "K" Sender
Power Supply:	10..30VDC
Power Current:	0.1 Amp. Max.
Scale:	200..700 °C
Subdivision scale:	10° C
Max. Deviation:	1%
Dimensions:	See sketch
Calibration:	Calibrated by the manufacturer prior to shipment.

*Please refer to the updated User Manual of your engine BRP-ROTAX® engine for the operational limits

Installation Instructions

- Install instruments in pilot's field of vision, free from vibration and glare.
- Protect the instruments against dampness and any kind of gasoline or acid.
- Pay attention to installation dimensions
- Wiring has to be carried out with good quality plastic-sheathed cable.
- When routing cables, prevent possible damage to cables from heat, vibration, shearing or crushing.
- Install a breaker or fuse of 1 Amp.

Instruments Terminals

- 1) (+) Red wire to positive terminal of battery.
- 2) (-) Black wire to negative terminal of battery.
- 3) Input to the EGT Sender.
- 4) Factory calibration input.

Wire Connections

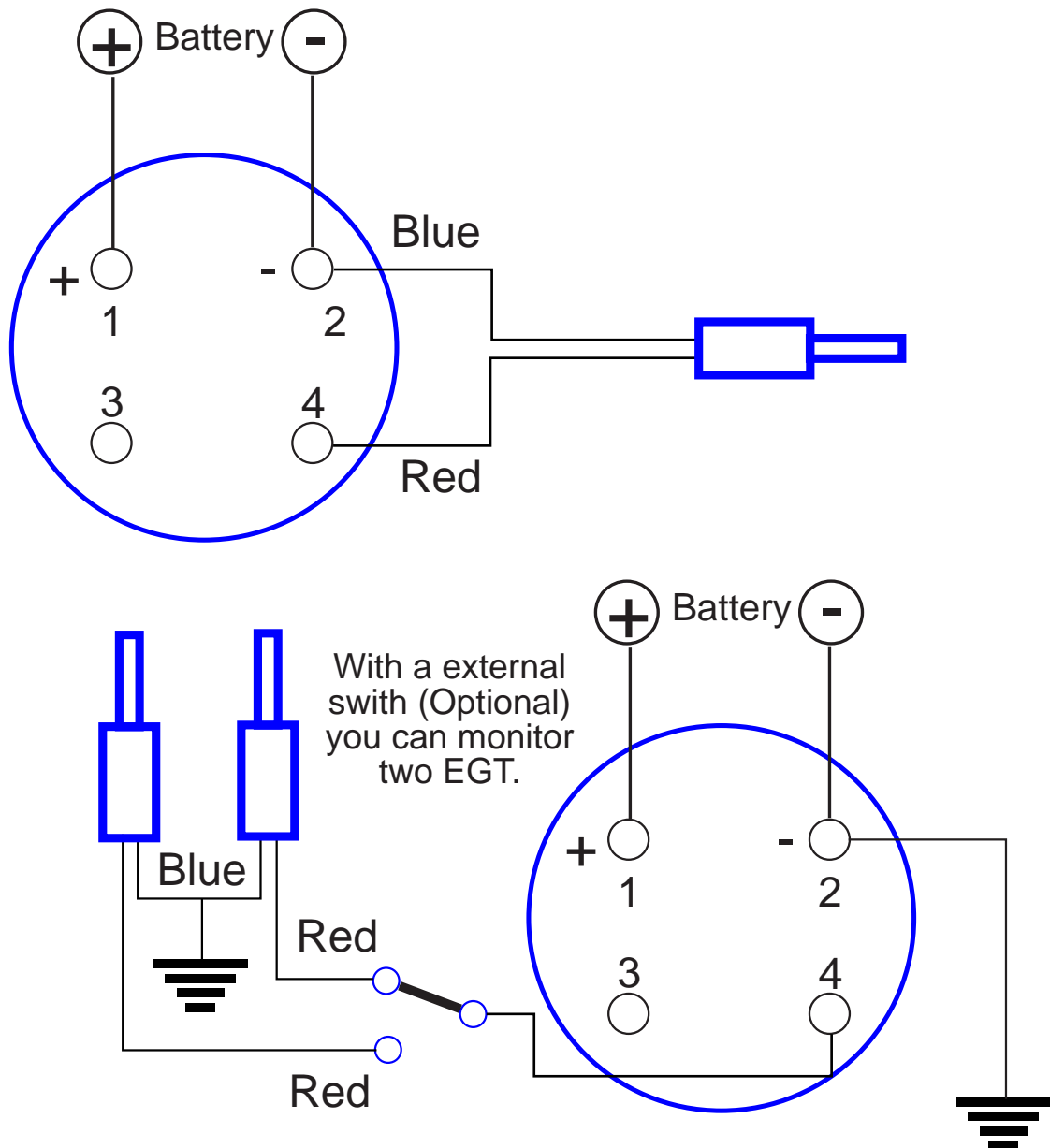

Sender

The sensors have to be installed in the exhaust manifold at a distance of 100 mm (4") from the exhaust valve.

The threads of the EGT sensors and pick-up of coolant have to be greased with Loctite ANTI-SEIZE, to ensure troublefree removal. Tightening torque: 20Nm (177in.lb.)

The Type K sender is a thermocouple consisting of two dissimilar conductors that contact each other at one or more spots. It produces a voltage when the temperature of one of the spots differs from the reference temperature at other parts of the circuit resistance which varies with the temperature. For this reason you should never cut the wires.

Two models are available:

IM-920

Has a M8 thread and can be installed directly on the M8 nuts that come from the factory on 914 engines and some 912. In the exhaust without nuts, your need weld 4xM8 nuts. Stainless steel protection. Wire length 3 meters.

IM-924

Probe type "K" Clamp type. Designed for 447/503/582 Rotax engines. No need weld nut, simply drill and tighten the clamp. Stainless steel protection. Wire length 2 meters.

IM-920



IM-924



Dimensions

