



CHT TEMPERATURE FOR ROTAX ENGINES 582. Diameter 52mm. °C IM-757

Preface

The IM-757 instruments have been designed especially to measure the Cylinder Head Temperature in Rotax® engines 582.

The IM-757 is available in 52 mm size.

Thanks to embedded operational amplifiers, this instrument has a high accuracy, but needs a power supply of 12V or 24V.

General Information

ATTENTION : The IM-757 has not undergone any safety or durability examination to Civil Aviation standards but does incorporate the latest technical development and has been thoroughly tested. Despite the Tachometer being a precision instrument, false indication or misinterpretation of data could occur. By utilizing this instrument the user acknowledges the possible danger and responsibility for all risks.

State of receipt

- Instruments packed in a plastic bag
- 4 attachment screws
- 3 Loose screws



Technical data

Case:	Plastic
Weight:	220g
Suitable for:	Type "J" Sender
Power Supply:	10..30VDC
Power Current:	0.1 Amp. Max.
Scale:	50..160 °C
Subdivision scale:	1° C
Max. Deviation:	1%
Dimensions:	See sketch
Calibration:	Calibrated by the manufacturer prior to shipment.
Red Zone*	From 150 to 160°C.
Yellow Zone*	50 to 110°C & 130 to 150°C
Green Zone*	110 to 130°C

*Please refer to the updated User Manual of your engine BRP-ROTAX® engine for the operational limits

Installation Instructions

- Install instruments in pilot's field of vision, free from vibration and glare.
- Protect the instruments against dampness and any kind of gasoline or acid.
- Pay attention to installation dimensions
- Wiring has to be carried out with good quality plastic-sheathed cable.
- When routing cables, prevent possible damage to cables from heat, vibration, shearing or crushing.
- Install a breaker or fuse of 1 Amp.

Instruments Terminals

- 1) (+) Red wire to positive terminal of battery.
- 2) (-) Black wire to negative terminal of battery.
- 3) Factory calibration input.
- 4) Input to the CHT Sender.

Wire Connections

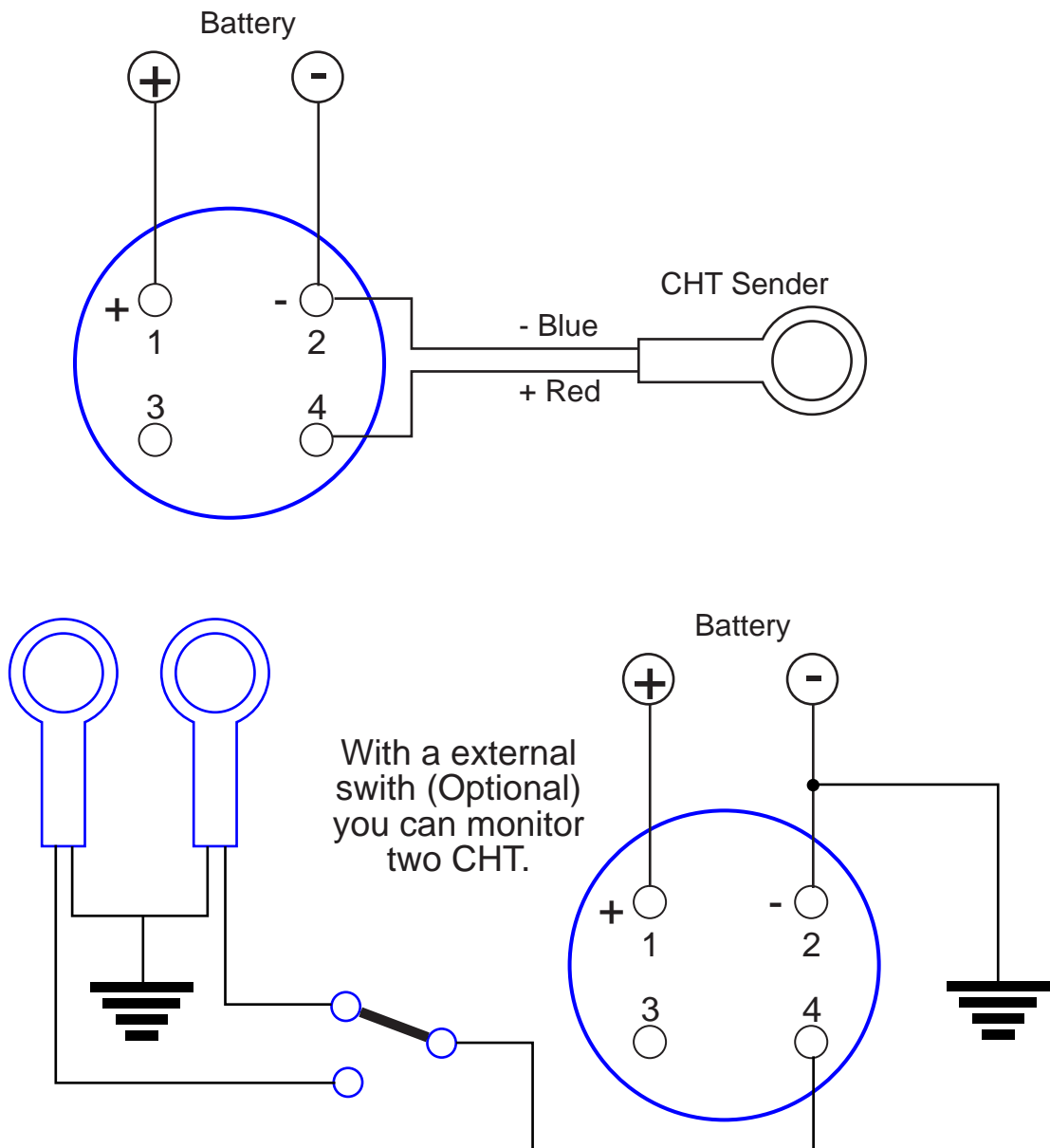

Sender

The Type J sender is a thermocouple consisting of two dissimilar conductors that contact each other at one or more spots. It produces a voltage when the temperature of one of the spots differs from the reference temperature at other parts of the circuit resistance which varies with the temperature.

For this reason you should never cut the wires.

Two models are available:

Ref IM-912 - Sender Type J length 2 meters

Ref IM-922 - Sender Type J length 3 meters



Dimensions

