



## CHT TEMPERATURE FOR ROTAX ENGINES 912ULS/914UL. Diameter 57mm. °C IM-539

### Preface

The IM-539 instruments have been designed especially to measure the Cylinder Head Temperature in Rotax® engines 912ULS (100HP) and 914UL.

The IM-539 is available in 57 mm size.

The instruments have been designed to work with both 12V and 24V systems.

The minimum instrumentation requirements for BRP ROTAX® four stroke engines include a gauge for continuous CHT monitorization.

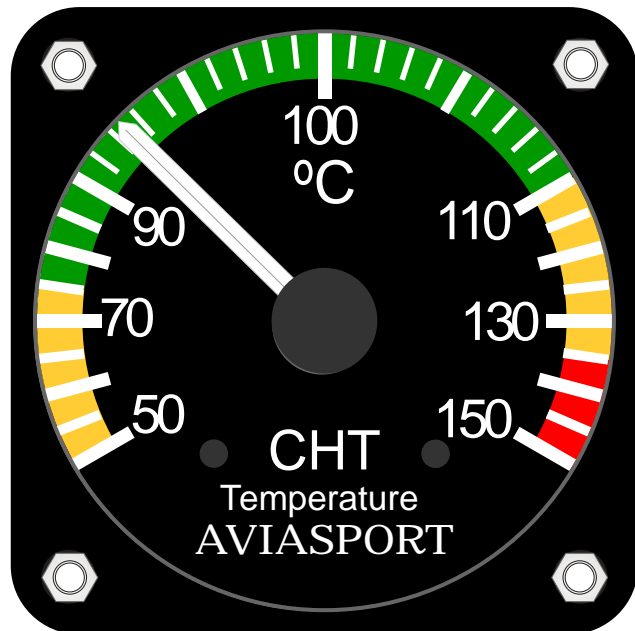

### General Information

**ATTENTION :** The IM-539 has not undergone any safety or durability examination to Civil Aviation standards but does incorporate the latest technical development and has been thoroughly tested. Despite the CHT being a precision instrument, false indication or misinterpretation of data could occur. By utilizing this instrument the user acknowledges the possible danger and responsibility for all risks.

### State of receipt

- Instruments packed in a plastic bag
- 4 attachment screws
- 3 Loose plugs

### Technical data

Case:	Plastic
Weight:	220g
Suitable for:	VDO Sender
Power Supply:	10..30VDC
Power Current:	0.1 Amp. Max.
Scale:	50..150 °C
Subdivision scale:	1°C
Max. Deviation:	2%
Dimensions:	See sketch
Calibration:	Calibrated by the manufacturer prior to shipment.

Red Zone*	From 135 to 150°C.
Yellow Zone*	50 to 75°C & 110 to 135°C
Green Zone*	75 to 110°C

\*Please refer to the updated User Manual of your engine BRP-ROTAX® engine for the operational limits

## Installation Instructions

- Install instruments in pilot's field of vision, free from vibration and glare.
- Protect the instruments against dampness and any kind of gasoline or acid.
- Pay attention to installation dimensions
- Wiring has to be carried out with good quality plastic-sheathed cable.
- When routing cables, prevent possible damage to cables from heat, vibration, shearing or crushing.
- Install a breaker or fuse of 1 Amp.

### Instruments Terminals

- 1) (+) Red wire to positive terminal of battery.
- 2) (-) Black wire to negative terminal of battery.
- 3) Input to the CHT Sender.
- 4) Factory calibration input.

## Wire Connections

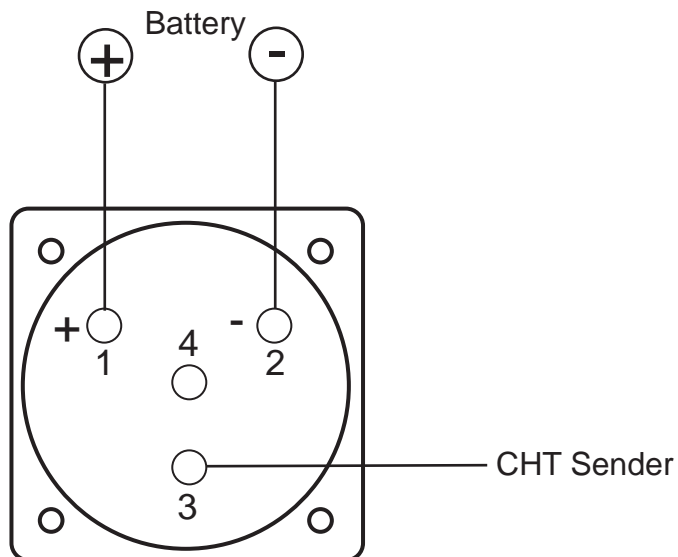

## Dimensions

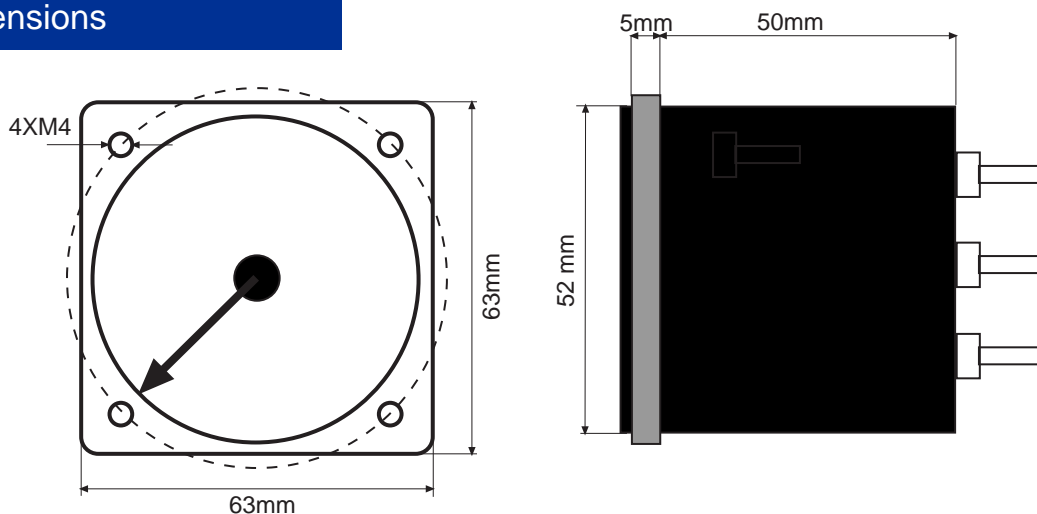

## Test & Calibration

The VDO sender is a resistance which varies with the temperature. To check the instrument you need a 1K potentiometer and multimeter. Adjust the potentiometer to the multimeter read 62.2 Ohm. Being careful not to turn the potentiometer, connect according to Figure 1. With 62.2 Ohm, the instrument should show 100 ° C. Try with other resistance values.

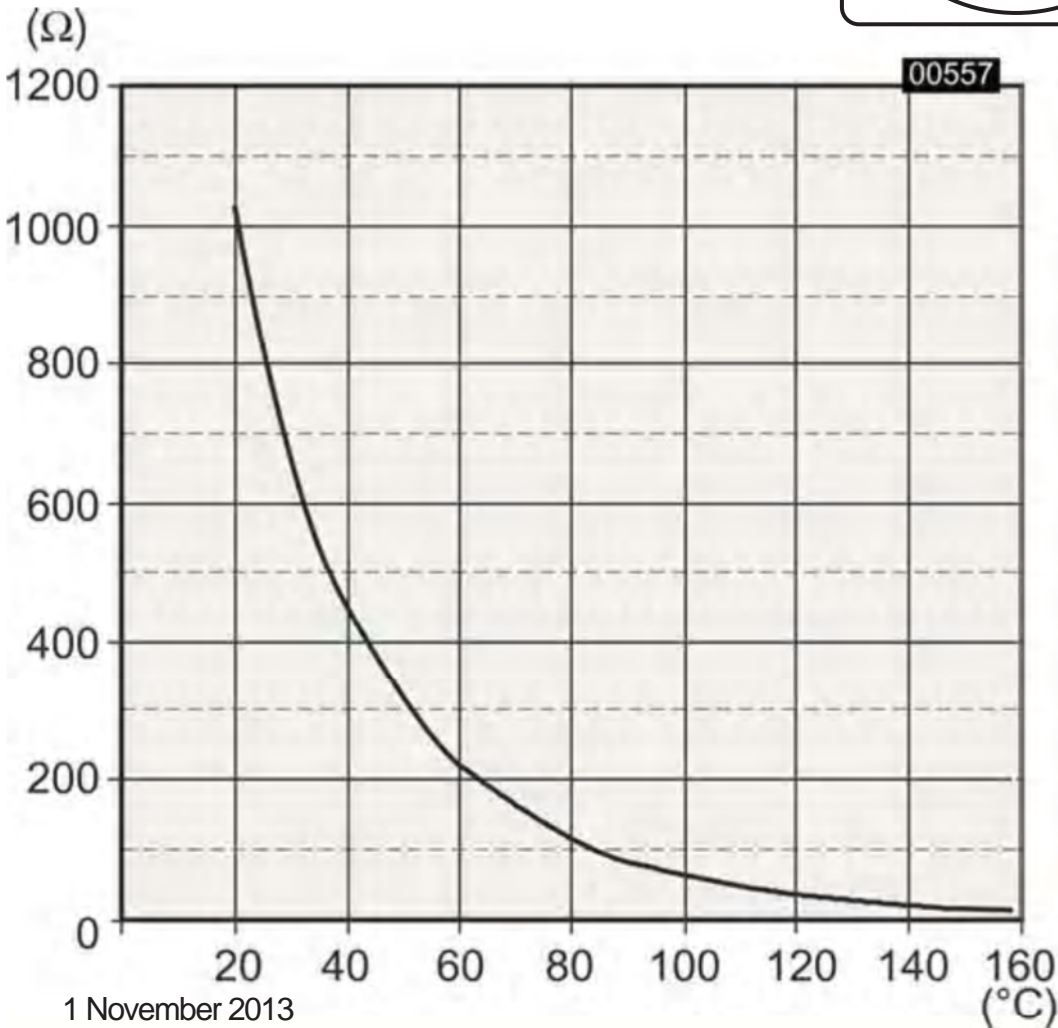
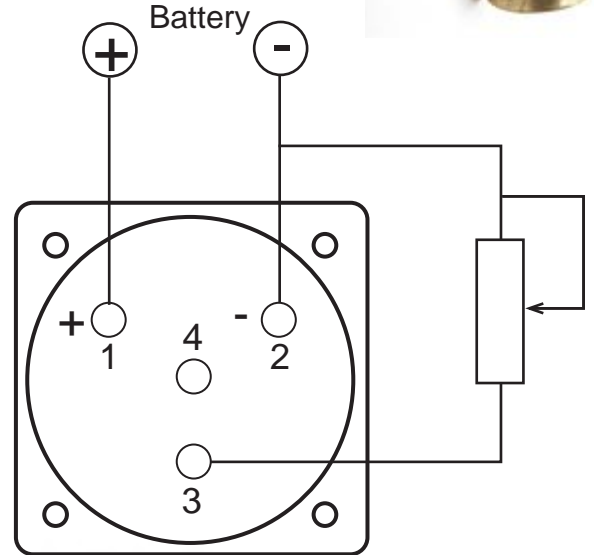

°C	OHM
50	322.8
60	165
70	133
80	112.5
90	83
100	62.2
110	47.5
120	36.5
130	28.9
140	23.1
150	18.6