



OIL TEMPERATURE FOR ROTAX ENGINES 912UL Diameter 57mm. °C. IM-528

Preface

The IM-528 instruments have been designed especially to measure the Oil Temperature in Rotax® engines 912UL.

The IM-528 is available in 57 mm size.

The instruments have been designed to work with both 12V and 24V systems.

The minimum instrumentation requirements for BRP ROTAX® four stroke engines include a gauge for continuous Oil Temperature monitorization.

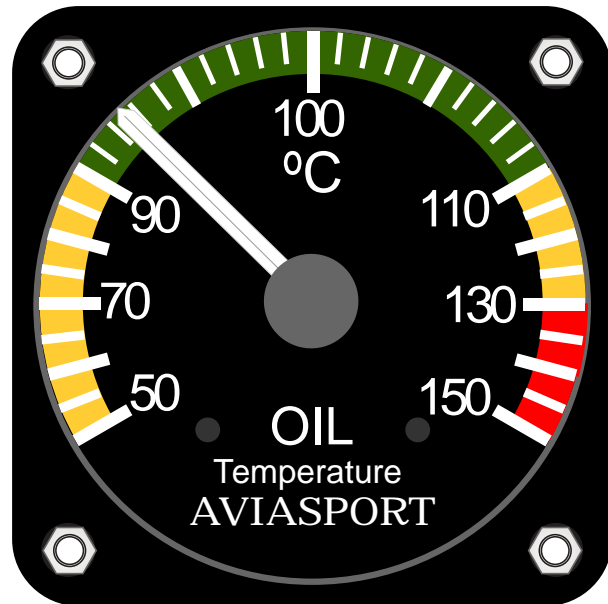

General Information

ATTENTION : The IM-528 has not undergone any safety or durability examination to Civil Aviation standards but does incorporate the latest technical development and has been thoroughly tested. Despite the the Oil Temperature being a precision instrument, false indication or misinterpretation of data could occur. By utilizing this instrument the user acknowledges the possible danger and responsibility for all risks.

State of receipt

- Instruments packed in a plastic bag
- 4 attachment screws
- 3 Loose plugs

Technical data

Case:	Plastic
Weight:	220g
Suitable for:	Rotax 912UL
Power Supply:	10..30VDC
Power Current:	0.1 Amp. Max.
Scale:	50..150°C
Subdivision scale:	1°C
Max. Deviation:	2%
Dimensions:	See sketch
Calibration:	Calibrated by the manufacturer prior to shipment.

Red Zone*	From 130 to 150°C.
Yellow Zone*	50 to 90°C & 110 to 130°C
Green Zone*	90 to 110°C

*Please refer to the updated User Manual of your engine BRP-ROTAX® engine for the operational limits

Installation Instructions

- Install instruments in pilot's field of vision, free from vibration and glare.
- Protect the instruments against dampness and any kind of gasoline or acid.
- Pay attention to installation dimensions
- Wiring has to be carried out with good quality plastic-sheathed cable.
- When routing cables, prevent possible damage to cables from heat, vibration, shearing or crushing.
- Install a breaker or fuse of 1 Amp.

Instruments Terminals

- 1) (+) Red wire to positive terminal of battery.
- 2) (-) Black wire to negative terminal of battery.
- 3) Input to the Oil Temperature Sender.
- 4) Factory calibration input.

Wire Connections

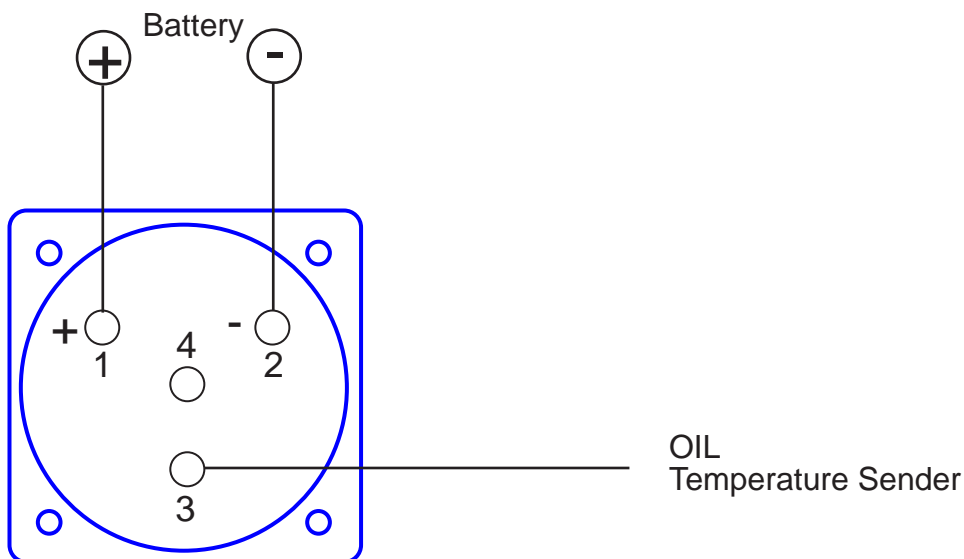

Dimensions

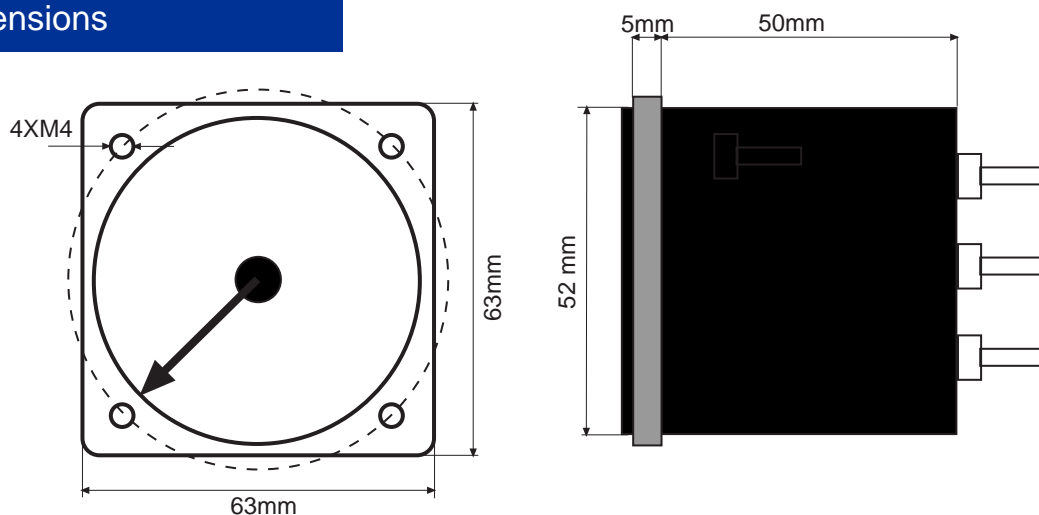

Test & Calibration

The OIL Temperature sender is a resistance which varies with the Oil Temperature. To check the instrument your need a 1000 Ohm potentiometer and a multimeter. Adjust the potentiometer to the multimeter read 62.2 Ohm. Being careful not to turn the potentiometer, connect according to Figure 1. With 62.2 Ohm, the instrument should show 100°C. Try with other resistance values.

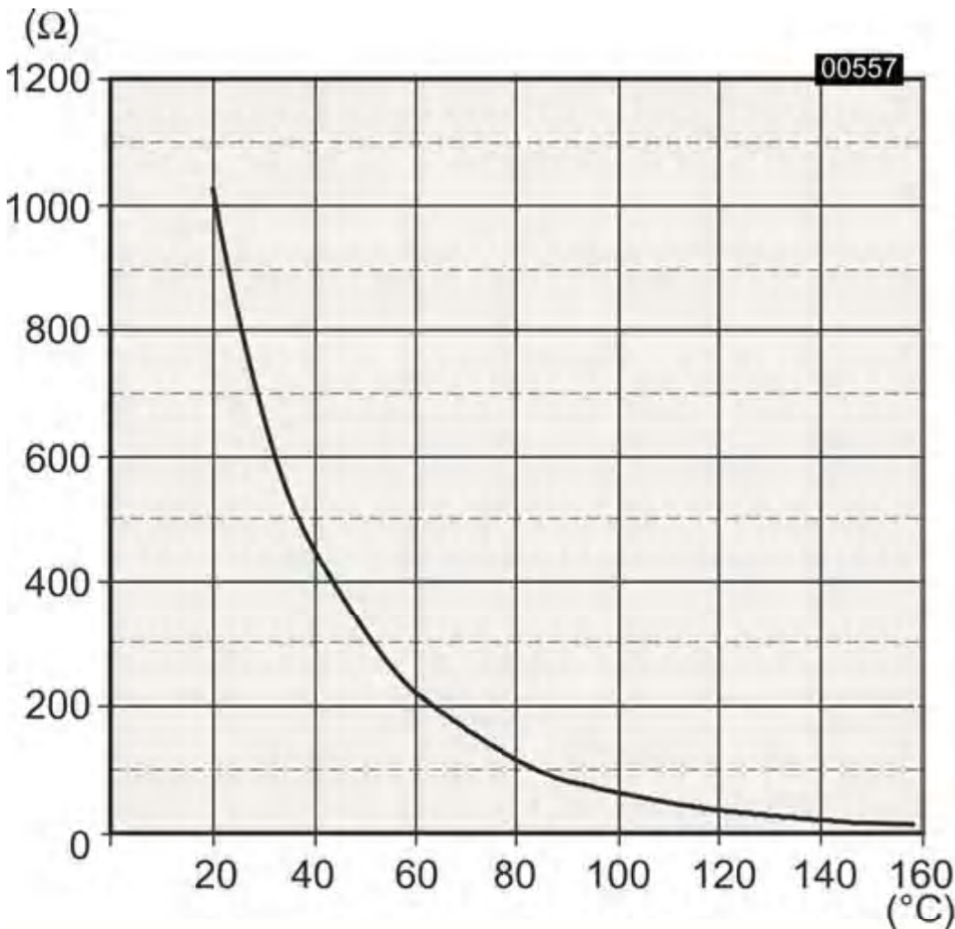
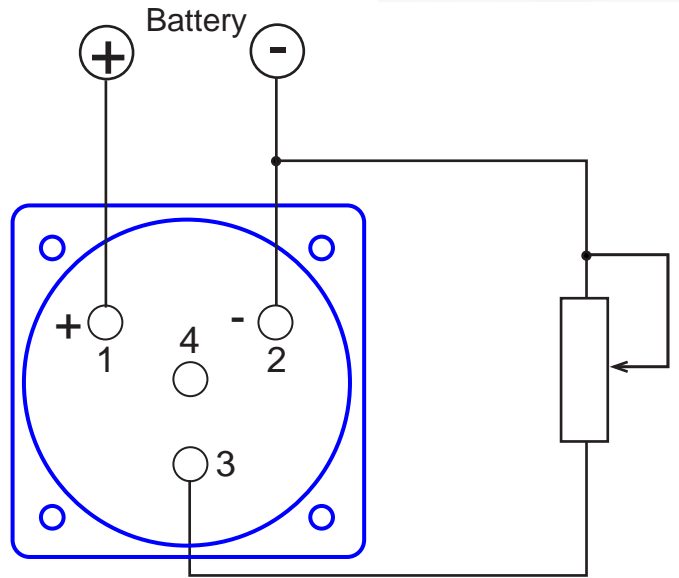

°C	OHM
50	322.8
60	165
70	133
80	112.5
90	83
100	62.2
110	47.5
120	36.5
130	28.9
140	23.1
150	18.6