



SERVICE BULLETIN

Inspection and/or replacement of the valve push-rod assy., rocker arm left and rocker arm right for ROTAX® Engine Type 912 i, 912 and 914 (Series)

ATA System: 72-30-00 Cylinder head

MANDATORY

1) Planning information

1.1) Applicability

Criterion A) All versions of the engine type:

Engine type	Serial number
912 iS Sport	from S/N 7 703 692 up to S/N 7 703 732 inclusive from S/N 7 704 201 up to S/N 7 704 354 inclusive
912 UL	from S/N 6 772 152 up to S/N 6 772 185 inclusive from S/N 9 580 001 up to S/N 9 580 262 inclusive
912 ULS	from S/N 6 785 971 up to S/N 6 786 198 inclusive from S/N 6 786 501 up to S/N 6 787 000 inclusive from S/N 9 569 001 up to S/N 9 569 690 inclusive from S/N 9 569 693 up to S/N 9 569 702 inclusive S/N 9 569 823
914 UL	from S/N 9 575 717 up to S/N 9 575 791 inclusive from S/N 9 576 001 up to S/N 9 576 468 inclusive

Criterion B) Spare parts:

Further all engines are affected, which have been equipped with valve push-rod assy. part no. 854861 during engine repair, maintenance or general overhaul as of June 08th, 2016.

NOTE: The valve push-rod assy. may have been removed from the initial engine and used on another one.
Engines with serial numbers higher than in criterion A have already been equipped with tested valve push-rod assy. and are therefore not affected.
For relevant information, see the maintenance records and/or the logbook.

For complete instructions and compliance to this Service Bulletin refer to Service Bulletin -SB-912 i-008/SB-912-070/SB-914-052, latest edition section 1.2 onward.

NOTE: Section 1.6) Approval: Is not required for engines of the type UL, iS (Series).
Section 3) Accomplishment: In addition: persons with adequate type-specific training.

d06498.fm

SERVICE BULLETIN

Translation into other languages might be performed in the course of language localization but does not lie within ROTAX® scope of responsibility.

In any case the original text in English language and the metric units are authoritative.

Symbols used

For meaning of the symbols used in this document, see chapter >Safety< of the latest Operators Manual for the respective engine type.



SERVICE BULLETIN

Inspection and/or replacement of the valve push-rod assy., rocker arm left and rocker arm right for ROTAX® Engine Type 912 i, 912 and 914 (Series)

ATA System: 72-30-00 Cylinder head

MANDATORY

1) Planning information

To obtain satisfactory results, procedures specified in this publication must be accomplished with accepted methods in accordance with prevailing legal regulations.

BRP-Rotax GmbH & Co KG cannot accept any responsibility for the quality of work performed in accomplishing the requirements of this publication.

1.1) Applicability

Criterion A) All versions of ROTAX® engines types:

Engine type	Serial number
912 iSc Sport	from S/N 4 417 438 up to S/N 4 417 441 inclusive from S/N 7 702 101 up to S/N 7 702 103 inclusive
912 A	from S/N 4 411 126 up to S/N 4 411 146 inclusive from S/N 4 411 401 up to S/N 4 411 492 inclusive
912 F	from S/N 4 413 066 up to S/N 4 413 067 inclusive from S/N 4 413 101 up to S/N 4 413 111 inclusive
912 S	from S/N 9 563 826 up to S/N 9 563 849 inclusive from S/N 9 564 301 up to S/N 9 564 508 inclusive from S/N 9 564 510 up to S/N 9 564 534 inclusive
914 F	from S/N 4 421 581 up to S/N 4 421 597 inclusive from S/N 4 421 701 up to S/N 4 421 833 inclusive

Criterion B) Spare parts:

Further all engines are affected, which have been equipped with valve push-rod assy. part no. 854861 during engine repair, maintenance or general overhaul as of June 08th, 2016.

NOTE: The valve push-rod assy. may have been removed from the initial engine and used on another one.
Engines with serial numbers higher than in criterion A have already been equipped with tested valve push-rod assy. and are therefore not affected.
For relevant information, see the maintenance records and/or the logbook.

SERVICE BULLETIN

1.2) Concurrent ASB/SB/SI and SL

In addition to this Service Bulletin the following Service Instructions must be observed and complied with:

Service Instructions-SI-912-009/SI-914-010, title „Introduction of a new rocker arm bushing“, current issue.

1.3) Reason

Due to deviations in the manufacturing process of the valve push-rod assy., partial wear on the rocker arm ball socket may occur. This wear might lead to a rocker arm cracking / fracture which in consequence may lead to a malfunction of the valve train. Possible effects are rough engine running or an unusual engine operating behaviour.

1.4) Subject

Inspection and/or replacement of the valve push-rod assy., rocker arm left and rocker arm right for ROTAX® Engine Type 912 i, 912 and 914 (Series).

1.5) Compliance

- Before the initial installation in an aircraft and/or the initial start-up thereafter.
- Carry out this inspection on the engines listed in section 1.1., according to the instructions in section 3 at the next ROTAX® scheduled maintenance event or within the next 25 hours of operation, but at the latest after 200 days (from the date of the initial issue of this Service Bulletin).
- At rough engine running, or unusual of engine operating behaviour carry out and inspection in accordance to this Service Bulletin before the next flight.

1.6) Approval

The technical content of this document is approved under the authority of DOA ref. EASA.21J.048.

1.7) Labor time

Estimated labor hours:

Engine installed in the aircraft - - - labor time will depend on airframe installation and therefore no estimate is available from the engine manufacturer.

1.8) Mass data

change of weight - - - none.

moment of inertia - - - unaffected.

1.9) Electrical load data

No change

1.10) Software modifications

No change

1.11) References

In addition to this technical information refer to current issue of

- all relevant Service Instructions (SI)
- Maintenance Manual Heavy (MMH)

NOTE:

The status of the Manuals can be determined by checking the table of amendments. The 1st column of this table shows the revision status. Compare this number to that listed on the ROTAX website: www.FLYROTAX.com. Updates and current revisions can be downloaded for free.

d06499.fm

SERVICE BULLETIN

1.12) Other Publications affected

None

1.13) Interchangeability of part

- all affected parts cannot further be used and must be returned F.O.B to ROTAX® Authorized distributors or their independent Service Centers.
- further sale, use or shipment of all valve push-rods part no. 854861 produced in the affected time period (as of June 08th, 2016 until October 02nd, 2017), in stores (e.g. replacement parts) are also affected, must undergo a visual inspection of valve push-rods as per section. 3.1.2 and if found not OK must be returned F.O.B. to ROTAX® Authorized distributors or their independent Service Centers.

2) Material Information

2.1) Material- cost and availability

Price and availability will be provided on request by ROTAX® Authorized Distributors or their independent Service Centers.

2.2) Company support information

- Shipping costs, downtime costs, loss of income, telephone costs etc. or costs of conversion to other engine versions or additional work, as for instance simultaneous engine overhauls are not covered in this scope and will not be borne or reimbursed by ROTAX®.

2.3) Material requirement per engine

parts requirement: Order parts as required for the relevant job task to be determined in section 3.).

Fig. no.		part no.	Qty/engine	Description	Application
2	required	840887	4	Allen screw M6x30 10.9	valve cover
2	parts for inspection	927941	4	Washer 6.0/12/1	valve cover
2		881920	1 Set	O-Ring set	valve cover
1	required	854861*	as required	Valve push-rod assy.	cylinder head
2	parts for replacement	854383	as required	Rocker arm left	cylinder head
2		854393	as required	Rocker arm right	cylinder head

* or relevant part as per supersedure history

2.4) Material requirement per spare part

None.

2.5) Rework of parts

None.

d06499.fm

SERVICE BULLETIN

2.6) Special tooling/lubricant-/adhesives-/sealing compound/price and availability

Price and availability will be supplied on request by ROTAX® Authorized Distributors or their independent Service Centers:

Description	Qty/engine	Part no.	Application
Valve spring loading jig	1*	877387**	valve spring
KLÜBER ISOFLEX TOPAS NB 5051	as required	898351***	rocker arm bearing

* Only needed if replacement task is required.

** or equivalent e.g. valve spring mounting device assy. part no. 877385.

*** or equivalent.

NOTICE

If using these special tools observe the manufacturers specifications.

SERVICE BULLETIN

3) Accomplishment/Instructions

- ROTAX® reserves the right to make any amendments to existing documents, which might become necessary due to this standardization, at the time of next revision or issue.

NOTE: Before maintenance, review the entire documentation to make sure you have a complete understanding of the procedure and requirements.

Accomplishment

All measures must be implemented and confirmed by at least one of the following persons or organizations:

- ROTAX® - Airworthiness representatives
- ROTAX® - Authorized Distributors or their independent Service Centers
- Persons approved by the respective Aviation Authority
- Persons with approved qualifications for the corresponding engine types. Only authorized persons (iRMT, Level Heavy Maintenance) are entitled to carry out this work.

NOTE: All work has to be performed in accordance with the relevant Maintenance Manual.

Safety notice



WARNING

Identifies an instruction which, if not followed, may cause serious injury or even fatal injury.



CAUTION

Identifies an instruction which, if not followed, may cause minor or moderate injury.

NOTICE

Identifies an instruction which, if not followed, may severely damage the engine or could void any warranty.

ENVIRONMENTAL NOTE

Environmental notes give you tips on environmental protection.

NOTE: Indicates supplementary information which may be needed to fully complete or understand an instruction.

3.1) Instructions

3.1.1) Removing valve covers

See [Fig. 2](#).

Step	Procedure
1	Loosen Allen screw (1) M6x30 with washer (2) from valve cover (3), and remove it together with large and small O-rings (4) and (5).

d06499.fm

SERVICE BULLETIN

3.1.2) Visual inspection of valve push-rods

Perform visual inspection of all push-rod ball sockets on all cylinder.
 Check for color. See Fig. 1.

Color	Evaluation
Silver surface	Valve push-rod is OK. No further action required for this valve push-rod.
Black surface	Valve push-rod is NOT OK. See section. 3.1.3) Replacement of affected parts.

3.1.3) Replacement of affected parts on affected cylinder positions (only in case visual inspection is NOT passed OK)

See [Fig. 2](#) and [Fig. 3](#).

On valve trains with valve push-rods found NOT OK the following steps need to be performed:

NOTE: On standard applications, the replacement of the push rods and rocker arms can be carried out with engine installed in aircraft.

Step	Procedure
1	Remove the spark plug connector and the four top spark plugs.

NOTICE

Prevent entering of foreign substance through spark plug hole.

Step	Procedure
2	Turn crankshaft so that the respective piston is exactly on ignition top dead center. NOTE: Only when you have an Criterion B) Spare parts affected engine and only if engine is equipped with collar cap nuts M8 wrench size 13: Loosen the external collar cap nut (6) for easier disassembling the rocker arm shaft.

NOTICE

Do not loosen the collar nuts M8. There is no reason to remove or loosening the M8 collar nuts the head stud may come loose requiring re-installation as per current Maintenance Manual. In the event that in loosening collar nuts M8, the stud becomes loose, retighten the stud to 3 Nm (26 in.lb).

Step	Procedure
3	Attach the support plate (12) to the valve spring loading jig part no. 877387 (7) with 2 hex. screws (13) M6x16 at the attachment points (14) on the cylinder heads.
4	Put adapters (15) on the valve spring loading jig.
5	Attach the valve spring loading jig on cylinder head and support plate with 2 Allen screws (8) M6x70 and depress both valves with 3 turns.

WARNING

When attaching the loading jig, take care to depress the valve with the valve spring simultaneously. Push the valve stem if need be, otherwise there is risk that the valve cotters will displace or may drop out.

d06499.fm

SERVICE BULLETIN

Step	Procedure
6	This will relieve the pressure from both hydraulic tappets. Now the rocker arm shaft (9) may be easily pulled out. Lift out both rocker arms (10) and (11).
7	Replace only affected parts as per section 2.3 . See also Fig. 3 .
8	Apply KLÜBER ISOFLEX TOPAS NB 5051 (16) on both push-rod ball sockets and contact areas of rocker arm and slide push-rod into the oil return tube (20).
9	Check bushing and rocker arm shaft according to latest Maintenance Manual Heavy.
10	Put oil on the rocker arm bushing.
11	Place rocker arm left (10) and rocker arm right (11) in cylinder head, apply KLÜBER ISOFLEX TOPAS NB 5051 (16) on rocker arm shaft (9) and insert it into its bearing support.
12	Loosen valve spring loading jig and support plate.
13	When removing the valve spring loading jig, make sure the adapter rings (15) do not jam on the valve spring retainer.
14	NOTE: Only when you have an Criterion B) Spare parts affected engine and only if engine is equipped with collar cap nuts M8 wrench size 13: Mount collar cap nut (6) according to latest Maintenance Manual Heavy or SI-912-025/SI-914-026/SI-912 i-010.
15	Lubricate all moving parts in the rocker arm space with engine oil or equivalent.

3.1.4) Install valve cover

See [Fig. 2](#).

Step	Procedure
1	Clean the sealing surface of cylinder head and valve cover with a suitable lint-free cloth or equivalent.
2	Insert new O-ring (4) 105x2.5 and O-ring (5) 6.4x1.8 into the valve cover (3).
3	Fit valve cover.

NOTICE

Between the valve covers a gap of min. 0,1 mm (.004 in.) must remain. The covers must not touch each other.

Step	Procedure
4	Tighten the new Allen screw (1) M6x30 with washer (2) to 10 Nm (89 in.lb).

WARNING

Carefully inspect the length of the valve cover screw. Inspect whether thread is damaged. If the screw is loose or the valve cover leaking, the oil will not return into the oil tank by "blow-by gas" and the oil system will not properly function. Improper installation of the valve cover could lead to loss of crankcase pressure.

d06499.fm

SERVICE BULLETIN

Step	Procedure
5	Refit the wiring and top spark plugs (17) and tighten. - If genuine ROTAX® spark plugs installed. Tighten the spark plugs to 16 Nm (142 in. lb.) on a cold engine. - If still old spark plug version NGK used tighten to 20 Nm (177 in.lb) or change all spark plugs to genuine ROTAX® spark plugs according to SI-912 i-013/SI-912-027/ SI-914-028. Install spark plug connector according to a marking sleeve.
6	Repeat the procedure on the remaining 3 cylinder heads.
7	Tighten the new Allen screw (1) M6x30 with washer (2) to 10 Nm (89 in.lb).

- Restore aircraft to original operating configuration.
- Connect negative terminal of aircraft battery.

3.2) Test run

Conduct test run. See chapter 12-20-00 of the latest Maintenance Manual Line for the respective engine type.

3.3) Summary

These instructions (section 3) have to be followed in accordance with the deadlines specified in section 1.5.

The execution of the mandatory Service Bulletin must be confirmed in the logbook.



A revision bar outside of the page margin indicates a change to text or graphic.

Translation into other languages might be performed in the course of language localization but does not lie within ROTAX® scope of responsibility.

In any case the original text in English language and the metric units are authoritative.

3.4) Inquiries

Inquiries regarding this Service Bulletin should be sent to the ROTAX® Authorized Distributor of your area.

A list of all ROTAX® Authorized Distributors or their independent Service Centers is provided on www.FLYROTAX.com.

SERVICE BULLETIN

4) Appendix

The following drawings should convey additional information:

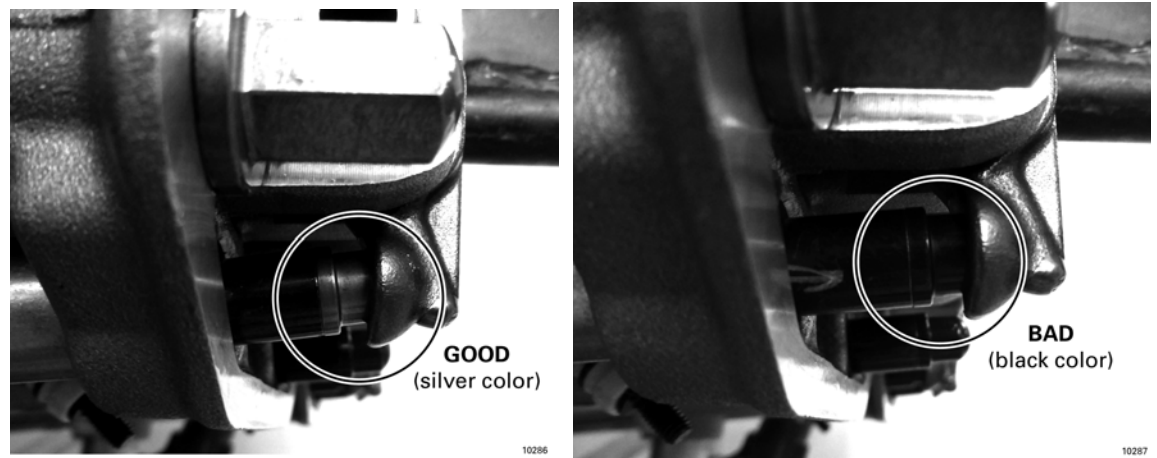

comparison of spare parts:

GOOD
(silver color)

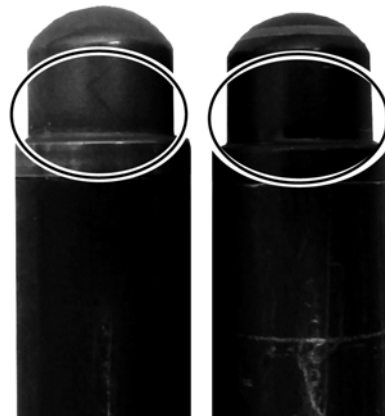

BAD
(black color)

Fig. 1
Visual inspection

SERVICE BULLETIN

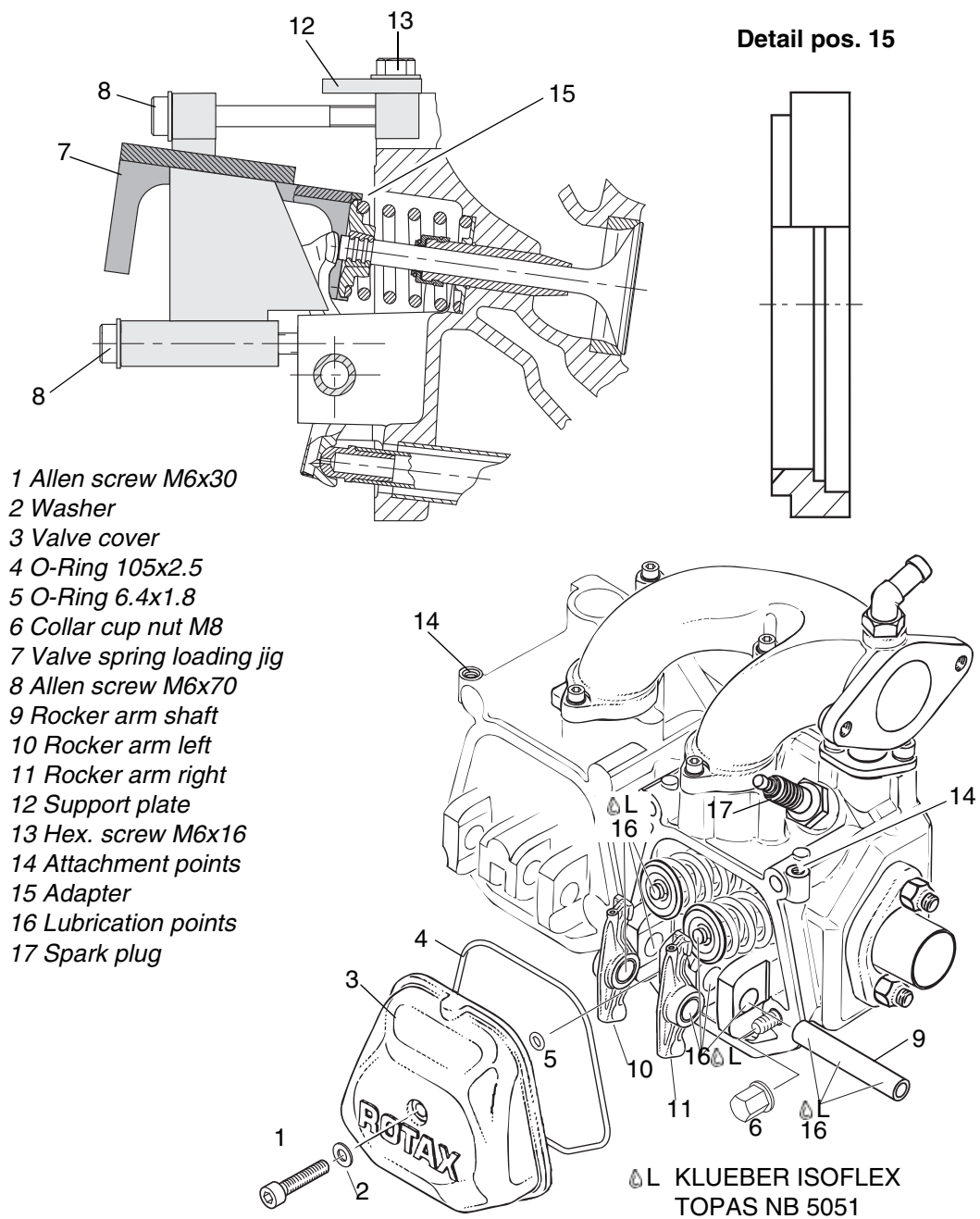
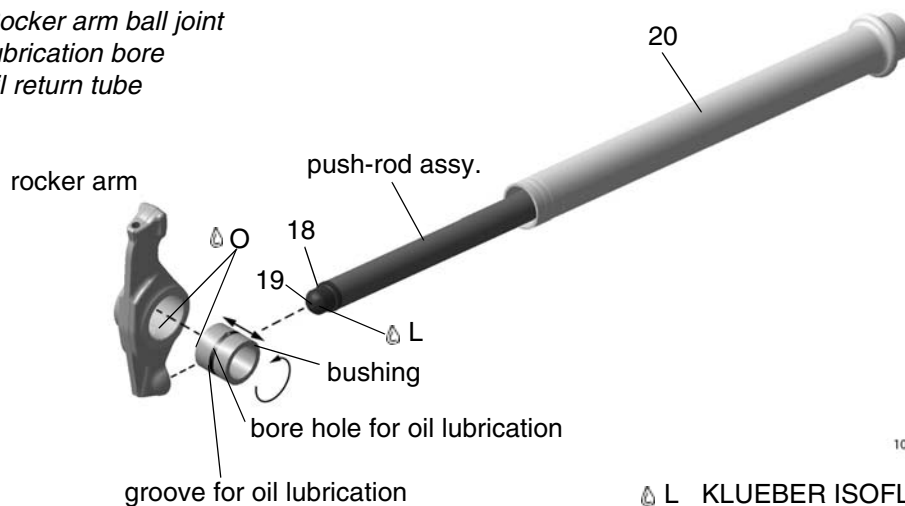

Fig. 2

d06499.fm

SERVICE BULLETIN

18 Rocker arm ball joint
19 Lubrication bore
20 Oil return tube



L KLUEBER ISOFLEX
TOPAS NB 5051
O ENGINE OIL

Fig. 3

NOTE: The illustrations in this document show the typical construction. They may not represent full detail or the exact shape of the parts which have the same or similar function.

Exploded views are **not technical drawings** and are for reference only. For specific detail, refer to the current documents of the respective engine type.