



Compliance with this Service Bulletin supersedes SB-912-065UL/SB-914-046UL, latest issue.

## SERVICE BULLETIN

# Exchange of floats on ROTAX® Engine Type 912 and 914 (Series)

ATA System: 73-00-00 Fuel system

### MANDATORY

#### Symbols used:

Please, pay attention to the following symbols throughout this document emphasizing particular information.

#### General note



Identifies an instruction which, if not followed, may cause serious injury or even fatal injury.



Identifies an instruction which, if not followed, may cause minor or moderate injury.

#### NOTICE

Denotes an instruction which if not followed, may severely damage the engine or could lead to suspension of warranty.

### ENVIRONMENT NOTE

Environment note gives you tips on environmental protection.

NOTE: Information useful for better handling.

A revision bar outside of the page margin indicates a change to text or graphic.

To obtain satisfactory results, procedures specified in this publication must be accomplished with accepted methods and prevailing government regulations.

BRP-Powertrain GmbH & Co KG. cannot be responsible for the quality of work performed in accomplishing the requirements of this publication

# SERVICE BULLETIN

## 1) Planning information

### 1.1) Applicability

All engines of Series 912 UL, 912 ULS and 914 UL are affected, if at least one of following criteria applies:

#### Criterion A) Engine Serial number:

Engine type	Serial number
912 UL	from S/N 6 770 733 up to S/N 6 771 484 inclusive
912 ULS	from S/N 6 780 228 up to S/N 6 783 917 inclusive
914 UL	from S/N 7 682 154 up to S/N 7 683 662 inclusive

#### Criterion B) Carburetors:

The part numbers and serial numbers of the carburetors:

Carburetors	Serial number
912 UL	1/3 part no. 892500 - from S/N 116434 up to S/N 144101 inclusive 2/4 part no. 892505 - from S/N 115846 up to S/N 143886 inclusive
912 ULS	1/3 part no. 892530 - from S/N 121087 up to S/N 143702 inclusive 2/4 part no. 892535 - from S/N 120980 up to S/N 143505 inclusive
914 UL	1/4 part no. 892520 - from S/N 116207 up to S/N 143799 inclusive 2/4 part no. 892525 - from S/N 120228 up to S/N 143310 inclusive

#### Criterion C) Spare parts:

Further all engines are affected, which have been equipped during engine repair, maintenance or general overhaul as of July 01, 2012 with floats with the part no. 861184, which have not been marked (see Service Bulletin AB-912-067/SB-914-048, current issue, chapter 3.3, page 7).

NOTE: The carburetor and/or the float may have been removed from the initial engine and used on another one.

Engines and/or carburetors with S/N higher than mentioned in criterion A or B have already been equipped with tested floats. To provide traceability these floats were marked as described in section 3.3 (refer to Service Bulletin SB-912-067/SB-914-048, latest revision). For relevant information, see the maintenance records and/or the logbook.

For complete instructions and compliance to this Service Bulletin refer to Service Bulletin-SB-912-067/SB-914-048, latest edition, section 1.2 onwards.

NOTE: Section 1.6) Approval: Is not required for engines of type UL (Series).  
Section 3) Accomplishment: In addition, persons with adequate type-specific training can perform the work.

d06140.fm



Compliance with this Service Bulletin supersedes SB-912-065/SB-914-046, latest issue.

## SERVICE BULLETIN

# Exchange of floats on ROTAX® Engine Type 912 and 914 (Series)

ATA System: 73-00-00 Fuel system

### MANDATORY

#### Symbols used:

Please, pay attention to the following symbols throughout this document emphasizing particular information.

#### General note



**Identifies an instruction which, if not followed, may cause serious injury or even fatal injury.**



**Identifies an instruction which, if not followed, may cause minor or moderate injury.**

#### NOTICE

**Denotes an instruction which if not followed, may severely damage the engine or could lead to suspension of warranty.**

### ENVIRONMENT NOTE

Environment note gives you tips on environmental protection.

NOTE: Information useful for better handling.

A revision bar outside of the page margin indicates a change to text or graphic.

To obtain satisfactory results, procedures specified in this publication must be accomplished with accepted methods and prevailing government regulations.

BRP-Powertrain GmbH & Co KG. cannot be responsible for the quality of work performed in accomplishing the requirements of this publication.

# SERVICE BULLETIN

## 1) Planning information

### 1.1) Applicability

All engines of Series 912 A, 912 F, 912 S and 914 F are affected, if at least one of following criteria applies:

#### Criterion A) Engine Serial number:

Engine type	Serial number
912 A	From S/N 4 410 957 up to S/N 4 411 048 inclusive
912 F	From S/N 4 413 008 up to S/N 4 413 041 inclusive
912 S	From S/N 4 924 408 up to S/N 4 924 838 inclusive
914 F	From S/N 4 421 136 up to S/N 4 421 403 inclusive

#### Criterion B) Carburetors:

The part numbers and serial numbers of the carburetors:

Carburetors	Serial number
912 A/F	1/3 part no. 892500 - from S/N 116434 up to S/N 144101 inclusive 2/4 part no. 892505 - from S/N 115846 up to S/N 143886 inclusive
912 S	1/3 part no. 892530 - from S/N 121087 up to S/N 143702 inclusive 2/4 part no. 892535 - from S/N 120980 up to S/N 143505 inclusive
914 F	1/4 part no. 892520 - from S/N 116207 up to S/N 143799 inclusive 2/4 part no. 892525 - from S/N 120228 up to S/N 143310 inclusive

#### Criterion C) Spare parts:

Further all engines are affected, which have been equipped during engine repair, maintenance or general overhaul as of July 01, 2012 with floats with the part no. 861184, which have not been marked (see page 7, chapter 3.3).

NOTE: The carburetor and/or the float may have been removed from the initial engine and used on another one.

Engines and/or carburetors with serial numbers higher than in criterion A or B have already been equipped with tested floats. To provide traceability the floats were marked as described in section 3.3.

For relevant information, see the maintenance records and/or the logbook.

### 1.2) Concurrent ASB/SB/SI and SL

In addition to this Service Bulletin the following Service Instruction must be observed and complied with:

- Service Instruction-SI-912-021/SI-914-023, „Inspection of carburetors“, current issue.

d06138.fm

## SERVICE BULLETIN

---

### 1.3) Reason

Due to a deviation in the manufacturing process some floats could absorb more fuel thus having more weight. This leads to a loss of float buoyancy and wrong regulation of the fuel in the float chamber. Possible effects may be a rough engine running, especially at low speeds and under circumstances loss of performance and/or fuel leakage in the area of the carburetor.

### 1.4) Subject

Exchange of floats on ROTAX® engine type 912 and 914 (Series).

### 1.5) Compliance

- Before the initial installation in an aircraft and/or the initial start-up thereafter.
- Carry out this exchange of the floats on the engines listed in section 1.1., according to the instructions in section 3 at the next BRP maintenance event or within the next 25 hours of operation, but at the latest after 60 days (from the date of the initial issue of this Service Bulletin).  
If parts needed for execution of this SB are not available, SB-912-065/SB-914-046 "Periodic inspection of the float buoyancy" may be repeated alternatively until parts are available.
- At rough engine running, especially at low engine speeds (crankshaft speed to 4000 rpm), fuel odor or fuel leakage carry out this exchange before the next flight.



**WARNING**

Non-compliance with these instructions could result in engine damages, personal injuries or even fatal injury.

### 1.6) Approval

The technical content of this document is approved under the authority of DOA ref. EASA.21J.048.

### 1.7) Labor time

Estimated labor time:

- engine installed in the aircraft: labor time will depend on installation and therefore no estimate is available from the engine manufacturer

### 1.8) Mass data

change of weight - - none.

moment of inertia- - - unaffected.

### 1.9) Electrical load data

no change

### 1.10) Software accomplishment summary

no change

d06138.fm

## SERVICE BULLETIN

---

### 1.11) References

In addition to this technical information refer to current issue of

- Maintenance Manual (MM) Heavy
- Maintenance Manual (MM) Line

NOTE: The status of manuals can be determined by checking the table of amendments of the Manual. The 1<sup>st</sup> column of this table shows the revision status. Compare this number to the one listed on the ROTAX® WebSite: [www.FLYROTAX.com](http://www.FLYROTAX.com). Updates and current revisions can be downloaded for free.

### 1.12) Other Publications affected

none

### 1.13) Interchangeability of parts

- All affected parts cannot further be used and have to be returned F.O.B to ROTAX® Authorized Distributors or their Service Centers.

## 2) Material Information

### 2.1) Material- cost and availability

Price and availability will be provided on request by ROTAX® Authorized Distributors or their Service Centers.

### 2.2) Company support information

- Any possible support from BRP-Powertrain will be provided on request by ROTAX® Authorized Distributors or their Service Centers.
- Replaced parts must be returned F.O.B to ROTAX® Authorized Distributors or their Service Centers.
- Shipping costs, downtime costs, loss of income, telephone costs etc. or costs of conversion to other engine versions or additional work, as for instance simultaneous engine overhauls, are not covered in this scope and will not be borne or reimbursed by ROTAX®.

## SERVICE BULLETIN

---

### 2.3) Material requirement per engine

Parts requirement for exchanging the floats and for restoring the initial configuration:

NOTE: Use only parts indicated in the following table.

Parts requirement for replacement of the floats:

Part no.	Qty /engine	Description	Application
861184	as required	Float (pair), guided	Engine type 912/914 Series
830728	2	Gasket	Float chamber 912/914 Series
631771	2	O-ring 15.6x1.78	Attachment screw 914 Series

### 2.4) Material requirement per spare part

none

### 2.5) Rework of parts

none

### 2.6) Special tooling/lubricant-/adhesives-/sealing compound

none

# SERVICE BULLETIN

## 3) Accomplishment/Instructions

**NOTE:** Before maintenance, review the entire documentation to make sure you have a complete understanding of the procedure and requirements.

### Accomplishment

All measures must be implemented and confirmed by at least one of the following persons or organizations:

- ROTAX® - Distributors or their Service Centers
- Persons with approved qualifications for the corresponding engine type. Only certified technicians (iRMT-Level: Line Maintenance) are qualified to work on these engines.

**NOTE:** All work has to be performed in accordance with the relevant Maintenance Manual.

### Safety notice

#### **WARNING**

Proceed with this work only in a non-smoking area and not close to sparks or open flames. Switch off ignition and secure engine against unintentional operation. Secure aircraft against unauthorized operation. Disconnect negative terminal of aircraft battery.

#### **WARNING**

Risk of scalds and burns! Allow engine to cool sufficiently and use appropriate safety gear while performing work.

### 3.1) General

Adhere to the installation instructions defined in the ROTAX® Installation Manual regarding the carburetor venting or purging and the drip tray.

#### **NOTICE**

Do not modify the floats!  
Should removal of a locking device (e.g. lock tabs, self-locking fasteners, etc.) be required during disassembly/assembly, always replace with a new one.

Step	Procedure
1	Check the criteria given on page 2, section 1.1, if the aircraft is affected by this SB.
2	Check the engine logbook and maintenance documentation, if this SB has already been accomplished.



# SERVICE BULLETIN

## 3.2) Removal of float chamber

See Fig. 2.

Preparation for dismantling the float chamber according to the installation instructions of the aircraft manufacturer.

Step	Procedure
1	Remove drip tray (1).
2	Visual inspection of the carburetor and its mechanical actuation.
3	Remove spring clip (5) or for ROTAX 914 Series remove safety wire, loosen cap screw (6) and remove with O-ring (7).
4	Remove float chamber (3), gasket (4) and the two floats (2)

## 3.3) Exchange of the floats

Exchange of the floats must be carried out according to the latest Maintenance Manual Heavy.

Only floats without markers have to be changed. Already marked floats (see Fig. 1) must not be changed.

Fig. 1



1 Marker

10223  
10224

NOTE: These markers have no effect on the function of the floats.

## 3.4) Installation of float chamber

See Fig. 1.

Step	Procedure
1	Remove the gasket (4) from the float chamber and for ROTAX 914 Series exchange the O-ring (7).
2	Install float chamber (3) with gasket (4) and both floats (2).

d06138.fm

## SERVICE BULLETIN

Step	Procedure
3	Close spring clip (5) or for ROTAX 914 Series install the attachment screw (6) including O-Ring (7) and apply safety wire. Tightening torque of attachment screw 5.5 Nm (48.7 in.lb).
4	Install drip tray (1) and/or accessories according to the instructions of the aircraft manufacturer.

Fig. 2

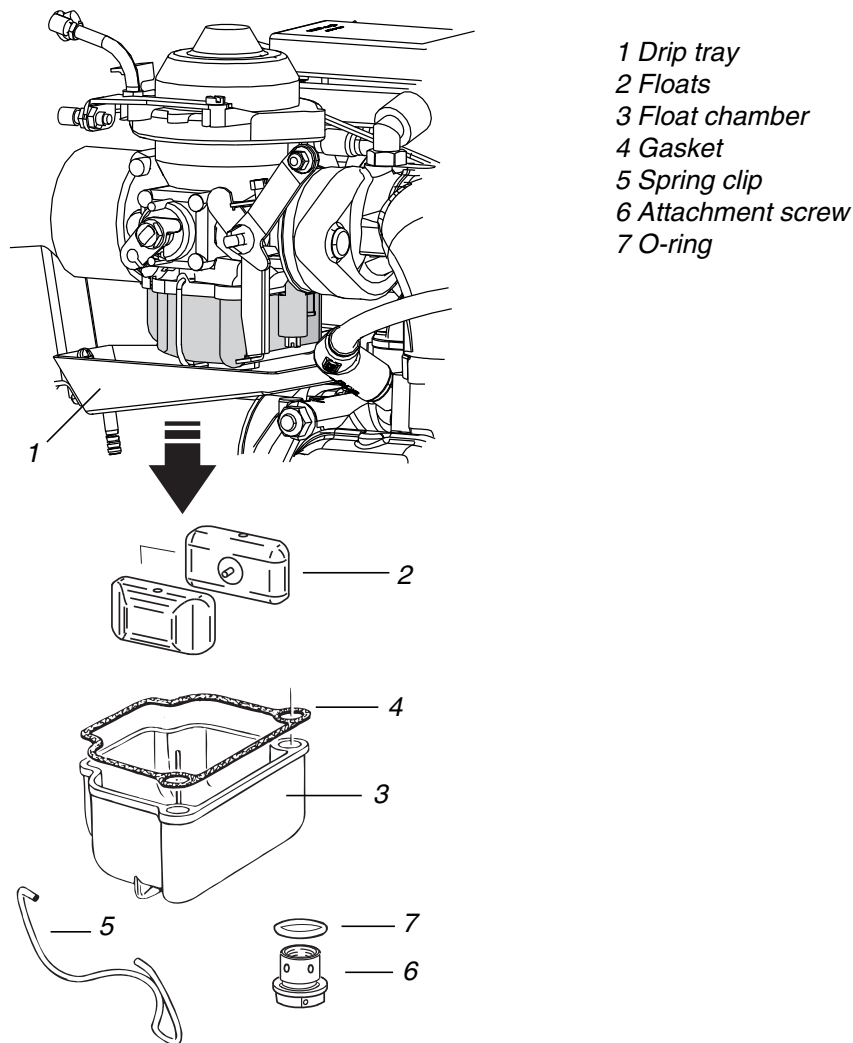

## SERVICE BULLETIN

---

### 3.5) Finishing work

- Restore aircraft to original operating configuration according to the instructions of the aircraft manufacturer.
- Connect negative terminal of aircraft battery.

### 3.6) Test run

Conduct test run. See also chapter 12-20-00 current issue of Maintenance Manual Line for the engine type 912/914 Series.

### 3.7) Summary

These instructions (section 3) have to be followed in accordance with the deadlines from section 1.5. The execution of the mandatory Service Bulletin must be confirmed in the logbook.

Approval of translation to best knowledge and judgement-in any case the original text in German language and the metric units (SI-system) are authoritative.

### 3.8) Enquiries

Enquiries regarding this Service Bulletin should be sent to the ROTAX® authorized distributor of your area. A list of all distributors is provided on [www.FLYROTAX.com](http://www.FLYROTAX.com).

**NOTE:**

The illustrations in this document show a typical construction. They may not represent full detail or the exact shape of the actual parts but have the same or similar function.

Exploded views are **no technical drawings** and are for reference only. For specific detail, refer to the current documents of the respective engine type.

## SERVICE BULLETIN

# Exchange of floats on ROTAX® Engine Type 912 and 914 (Series)

ATA System: 73-00-00 Fuel system

### MANDATORY

#### Symbols used:

Please, pay attention to the following symbols throughout this document emphasizing particular information.

#### General note



**Identifies an instruction which, if not followed, may cause serious injury or even fatal injury.**



**Identifies an instruction which, if not followed, may cause minor or moderate injury.**

#### NOTICE

**Denotes an instruction which if not followed, may severely damage the engine or could lead to suspension of warranty.**

### ENVIRONMENT NOTE

Environment note gives you tips on environmental protection.

NOTE: Information useful for better handling.

| A revision bar outside of the page margin indicates a change to text or graphic.

To obtain satisfactory results, procedures specified in this publication must be accomplished with accepted methods and prevailing government regulations.

BRP-Powertrain GmbH & Co KG. cannot be responsible for the quality of work performed in accomplishing the requirements of this publication.

# SERVICE BULLETIN

## 1) Planning information

### 1.1) Applicability

All engines of Series 912 A, 912 F, 912 S and 914 F are affected, if at least one of following criteria applies:

#### Criterion A) Engine Serial number:

Engine type	Serial number
912 A	From S/N 4 410 957 up to S/N 4 411 048 inclusive
912 F	From S/N 4 413 008 up to S/N 4 413 041 inclusive
912 S	From S/N 4 924 408 up to S/N 4 924 838 inclusive
914 F	From S/N 4 421 136 up to S/N 4 421 403 inclusive

#### Criterion B) Carburetors:

The part numbers and serial numbers of the carburetors:

Carburetors	Serial number
912 A/F	1/3 part no. 892500 - from S/N 116434 up to S/N 144101 inclusive 2/4 part no. 892505 - from S/N 115846 up to S/N 143886 inclusive
912 S	1/3 part no. 892530 - from S/N 121087 up to S/N 143702 inclusive 2/4 part no. 892535 - from S/N 120980 up to S/N 143505 inclusive
914 F	1/4 part no. 892520 - from S/N 116207 up to S/N 143799 inclusive 2/4 part no. 892525 - from S/N 120228 up to S/N 143310 inclusive

#### Criterion C) Spare parts:

Further all engines are affected, which have been equipped during engine repair, maintenance or general overhaul as of July 01, 2012 with floats with the part no. 861184, which have not been marked (see page 7, chapter 3.3).

NOTE: The carburetor and/or the float may have been removed from the initial engine and used on another one.

Engines and/or carburetors with serial numbers higher than in criterion A or B have already been equipped with tested floats. To provide traceability the floats were marked as described in section 3.3.

For relevant information, see the maintenance records and/or the logbook.

### 1.2) Concurrent ASB/SB/SI and SL

In addition to this Service Bulletin the following Service Instruction must be observed and complied with:

- Service Instruction-SI-912-021/SI-914-023, „Inspection of carburetors“, current issue.

d06138.fm

## SERVICE BULLETIN

---

### 1.3) Reason

Due to a deviation in the manufacturing process some floats could absorb more fuel thus having more weight. This leads to a loss of float buoyancy and wrong regulation of the fuel in the float chamber. Possible effects may be a rough engine running, especially at low speeds and under circumstances loss of performance and/or fuel leakage in the area of the carburetor.

### 1.4) Subject

Exchange of floats on ROTAX® engine type 912 and 914 (Series).

### 1.5) Compliance

- Before the initial installation in an aircraft and/or the initial start-up thereafter.
- Carry out this exchange of the floats on the engines listed in section 1.1., according to the instructions in section 3 at the next BRP maintenance event or within the next 25 hours of operation, but at the latest after 60 days (from the date of the initial issue of this Service Bulletin).  
If parts needed for execution of this SB are not available, SB-912-065/SB-914-046 "Periodic inspection of the float buoyancy" may be repeated alternatively until parts are available.
- At rough engine running, especially at low engine speeds (crankshaft speed to 4000 rpm), fuel odor or fuel leakage carry out this exchange before the next flight.



Non-compliance with these instructions could result in engine damages, personal injuries or even fatal injury.

### 1.6) Approval

The technical content of this document is approved under the authority of DOA ref. EASA.21J.048.

### 1.7) Labor time

Estimated labor time:

- engine installed in the aircraft: labor time will depend on installation and therefore no estimate is available from the engine manufacturer

### 1.8) Mass data

change of weight - - none.  
moment of inertia- - - unaffected.

### 1.9) Electrical load data

no change

### 1.10) Software accomplishment summary

no change

d06138.fm

## SERVICE BULLETIN

---

### 1.11) References

In addition to this technical information refer to current issue of

- Maintenance Manual (MM) Heavy
- Maintenance Manual (MM) Line

NOTE: The status of manuals can be determined by checking the table of amendments of the Manual. The 1<sup>st</sup> column of this table shows the revision status. Compare this number to the one listed on the ROTAX® WebSite: [www.FLYROTAX.com](http://www.FLYROTAX.com). Updates and current revisions can be downloaded for free.

### 1.12) Other Publications affected

none

### 1.13) Interchangeability of parts

- All affected parts cannot further be used and have to be returned F.O.B to ROTAX® Authorized Distributors or their Service Centers.

## 2) Material Information

### 2.1) Material- cost and availability

Price and availability will be provided on request by ROTAX® Authorized Distributors or their Service Centers.

### 2.2) Company support information

- Any possible support from BRP-Powertrain will be provided on request by ROTAX® Authorized Distributors or their Service Centers.
- Replaced parts must be returned F.O.B to ROTAX® Authorized Distributors or their Service Centers.
- Shipping costs, downtime costs, loss of income, telephone costs etc. or costs of conversion to other engine versions or additional work, as for instance simultaneous engine overhauls, are not covered in this scope and will not be borne or reimbursed by ROTAX®.

## SERVICE BULLETIN

---

### 2.3) Material requirement per engine

Parts requirement for exchanging the floats and for restoring the initial configuration:

NOTE: Use only parts indicated in the following table.

Parts requirement for replacement of the floats:

Part no.	Qty /engine	Description	Application
861184	as required	Float (pair), guided	Engine type 912/914 Series
830728	2	Gasket	Float chamber 912/914 Series
631771	2	O-ring 15.6x1.78	Attachment screw 914 Series

### 2.4) Material requirement per spare part

none

### 2.5) Rework of parts

none

### 2.6) Special tooling/lubricant-/adhesives-/sealing compound

none



# SERVICE BULLETIN

## 3) Accomplishment/Instructions

**NOTE:** Before maintenance, review the entire documentation to make sure you have a complete understanding of the procedure and requirements.

### Accomplishment

All measures must be implemented and confirmed by at least one of the following persons or organizations:

- ROTAX® - Distributors or their Service Centers
- Persons with approved qualifications for the corresponding engine type. Only certified technicians (iRMT-Level: Line Maintenance) are qualified to work on these engines.

**NOTE:** All work has to be performed in accordance with the relevant Maintenance Manual.

### Safety notice

#### **WARNING**

Proceed with this work only in a non-smoking area and not close to sparks or open flames. Switch off ignition and secure engine against unintentional operation. Secure aircraft against unauthorized operation. Disconnect negative terminal of aircraft battery.

#### **WARNING**

Risk of scalds and burns! Allow engine to cool sufficiently and use appropriate safety gear while performing work.

### 3.1) General

Adhere to the installation instructions defined in the ROTAX® Installation Manual regarding the carburetor venting or purging and the drip tray.

#### **NOTICE**

Do not modify the floats!  
Should removal of a locking device (e.g. lock tabs, self-locking fasteners, etc.) be required during disassembly/assembly, always replace with a new one.

Step	Procedure
1	Check the criteria given on page 2, section 1.1, if the aircraft is affected by this SB.
2	Check the engine logbook and maintenance documentation, if this SB has already been accomplished.

# SERVICE BULLETIN

### 3.2) Removal of float chamber

See Fig. 2.

Preparation for dismantling the float chamber according to the installation instructions of the aircraft manufacturer.

Step	Procedure
1	Remove drip tray (1).
2	Visual inspection of the carburetor and its mechanical actuation.
3	Remove spring clip (5) or for ROTAX 914 Series remove safety wire, loosen cap screw (6) and remove with O-ring (7).
4	Remove float chamber (3), gasket (4) and the two floats (2)

### 3.3) Exchange of the floats

Exchange of the floats must be carried out according to the latest Maintenance Manual Heavy.

Only floats without markers have to be changed. Already marked floats (see Fig. 1) must not be changed.

Fig. 1



1 Marker

10223  
10224

NOTE: These markers have no effect on the function of the floats.

### 3.4) Installation of float chamber

See Fig. 1.

Step	Procedure
1	Remove the gasket (4) from the float chamber and for ROTAX 914 Series exchange the O-ring (7).
2	Install float chamber (3) with gasket (4) and both floats (2).

d06138.fm

## SERVICE BULLETIN

Step	Procedure
3	Close spring clip (5) or for ROTAX 914 Series install the attachment screw (6) including O-Ring (7) and apply safety wire. Tightening torque of attachment screw 5.5 Nm (48.7 in.lb).
4	Install drip tray (1) and/or accessories according to the instructions of the aircraft manufacturer.

Fig. 2

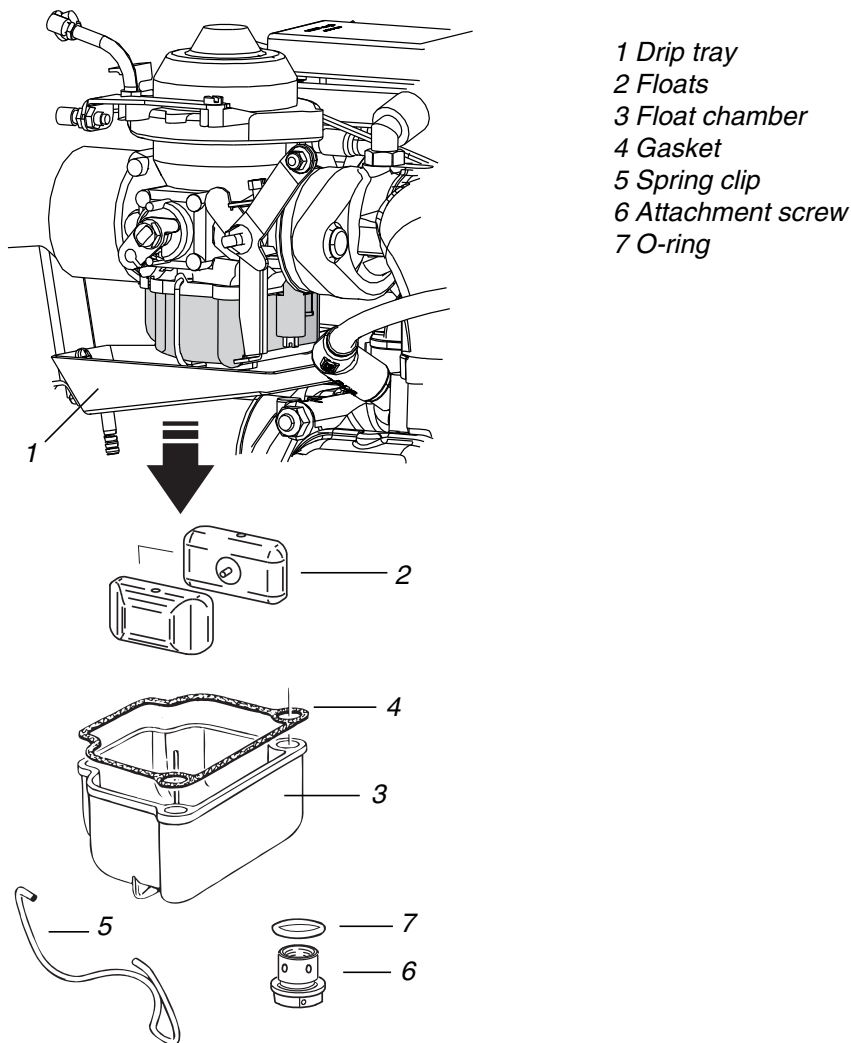

## SERVICE BULLETIN

---

### 3.5) Finishing work

- Restore aircraft to original operating configuration according to the instructions of the aircraft manufacturer.
- Connect negative terminal of aircraft battery.

### 3.6) Test run

Conduct test run. See also chapter 12-20-00 current issue of Maintenance Manual Line for the engine type 912/914 Series.

### 3.7) Summary

These instructions (section 3) have to be followed in accordance with the deadlines from section 1.5. The execution of the mandatory Service Bulletin must be confirmed in the logbook.

Approval of translation to best knowledge and judgement-in any case the original text in German language and the metric units (SI-system) are authoritative.

### 3.8) Enquiries

Enquiries regarding this Service Bulletin should be sent to the ROTAX® authorized distributor of your area. A list of all distributors is provided on [www.FLYROTAX.com](http://www.FLYROTAX.com).

**NOTE:**

The illustrations in this document show a typical construction. They may not represent full detail or the exact shape of the actual parts but have the same or similar function.

Exploded views are **no technical drawings** and are for reference only. For specific detail, refer to the current documents of the respective engine type.