



| This ASB revises ASB-912-061UL dated 26 May 2012

ALERT SERVICE BULLETIN

Replacement of the pressure side fuel hose at fuel pump part no. 893114 for ROTAX® Engine Type 912 (Series)

ATA System: 73-00-00 Fuel system

MANDATORY

Symbols used:

Please, pay attention to the following symbols throughout this document emphasizing particular information.

General note



Identifies an instruction which, if not followed, may cause serious injury or even fatal injury.



Identifies an instruction which, if not followed, may cause minor or moderate injury.

NOTICE

Denotes an instruction which if not followed, may severely damage the engine or could lead to suspension of warranty.

ENVIRONMENT NOTE

Environment note gives you tips and behaviors to environmental protection.

NOTE:

Information useful for better handling.

|

A revision bar outside of the page margin indicates a change to text or graphic.

ALERT SERVICE BULLETIN

1) Planning information

1.1) Applicability

All versions of the engine type:

Engine type	Serial number
912 UL	from S/N 6,770.549 up to S/N 6,770.552 inclusive/6,770.674 up to 6,770.685 inclusive
912 ULS	from S/N 6,779.365 up to S/N 6,779.367 inclusive/6,779.378 up to 6,779.382 inclusive/6,779.522 up to 6,779.553 inclusive/6,779.560/6,779.561/6,779.582 up to 6,779.601 inclusive/6,779.603 up to 6,779.623 inclusive/6,779.676 up to 6,779.705 inclusive/6,779.709/6,779.853 up to 6,779.882 inclusive/6,779.890 up to 6,779.893 inclusive/6,779.908 up to 6,779.913 inclusive/6,779.962 up to 6,779.991 inclusive/6,780.017 up to 6,780.019 inclusive/6,780.053/6,780.054/6,780.064 up to 6,780.072 inclusive/6,780.074/6,780.075/6,780.077 up to 6,780.079 inclusive/6,780.087

if they are equipped with the genuine ROTAX® fuel pump part no. 893114.

In addition, are also affected, all fuel pumps part no. 893114 with S/N 12.0261/12.0262/11.3117 up to 11.3122 inclusive/11.3124 up to 11.3127 inclusive/11.3131 up to 11.3135 inclusive/11.3140/11.3142/11.3145/11.3156/11.3158 up to 11.3160 inclusive/11.3174/11.3175/11.3186 up to 11.3225 inclusive/11.3252/11.3267 up to 11.3270 inclusive/11.3297 up to 11.3300 inclusive/11.3302 up to 11.3305 inclusive/11.4036 up to 11.4155 inclusive/11.4157/11.4159/11.4164/11.4186 up to 11.4195 inclusive/11.4206 up to 11.4235 inclusive/11.4244 up to 11.4246 inclusive/11.4256 up to 11.4265 inclusive/11.4284/11.4306 up to 11.4316 inclusive/11.4318/11.4319/11.4321/11.4322/11.4327/11.4331 up to 11.4335 inclusive/11.4516/11.4545/11.4549 up to 11.4552 inclusive/11.4554/11.4555/11.4566 up to 11.4585 inclusive, delivered as spare parts or installed at engine maintenance/general overhaul.

NOTE: Fuel pumps part no. 893114 with the following serial number (S/N) that were installed in the above-mentioned engine and delivered as spare parts are also affected.

- S/N 11.3117 up to S/N 11.3325 inclusive
- S/N 11.4036 up to S/N 11.4355 inclusive
- S/N 11.4516 up to S/N 11.4595 inclusive
- S/N 12.0251 up to S/N 12.0270 inclusive

In addition, are also affected, all fuel hose with part no. 874335, as spare parts or installed at engine maintenance/general overhaul.

For complete instruction and compliance to this Alert Service Bulletin refer to Alert Service Bulletin ASB-912-061, latest edition section 1.2 onward.

NOTE: Section 1.6) Approval: Is not required for engines of the type UL (series).
Section 3) Accomplishment: In addition: persons with adequate type-specific training.

d05141.fm



| This ASB revises ASB-912-061 dated 26 May 2012

ALERT SERVICE BULLETIN

Replacement of the pressure side fuel hose at fuel pump part no. 893114 for ROTAX® Engine Type 912 (Series)

ATA System: 73-00-00 Fuel system

MANDATORY

Symbols used:

Please, pay attention to the following symbols throughout this document emphasizing particular information.

General note



Identifies an instruction which, if not followed, may cause serious injury or even fatal injury.



Identifies an instruction which, if not followed, may cause minor or moderate injury.

NOTICE

Denotes an instruction which if not followed, may severely damage the engine or could lead to suspension of warranty.

ENVIRONMENT NOTE

Environment note gives you tips and behaviors to environmental protection.

NOTE:

Information useful for better handling.

|

A revision bar outside of the page margin indicates a change to text or graphic.

ALERT SERVICE BULLETIN

1) Planning information

1.1) Applicability

All versions of the engine type:

Engine type	Serial number
912 A2	S/N 4,410.956
912 F3	from S/N 4,413.000 up to S/N 4,413.002 inclusive / S/N 4,413.005 up to S/N 4,413.007 inclusive
912 S2	from S/N 4,924.331 up to S/N 4,924.334 inclusive / S/N 4,924.356 up to S/N 4,924.358 inclusive / S/N 4,924.378 up to S/N 4,924.381 inclusive / S/N 4,924.385 up to S/N 4, 924.386 inclusive / S/N 4,924.391/
912 S3	from S/N 4,924.354 up to S/N 4,924.355 inclusive / S/N 4,924.366 up to S/N 4,924.377 inclusive / S/N 4,924.382 up to S/N 4,924.384 inclusive / S/N 4,924.387 up to S/N 4,924.390 inclusive / S/N 4,924.392 up to S/N 4,924.402 inclusive /

if they are equipped with the genuine ROTAX® fuel pump part no. 893114.
See [Fig. 1](#)

In addition, are also affected, all fuel pumps part no. 893114 with S/N 12.0261/12.0262/11.3117 up to 11.3122 inclusive/11.3124 up to 11.3127 inclusive/ 11.3131 up to 11.3135 inclusive/11.3140/11.3142/11.3145/11.3156/11.3158 up to 11.3160 inclusive/11.3174/11.3175/11.3186 up to 11.3225 inclusive/11.3252/11.3267 up to 11.3270 inclusive/ 11.3297 up to 11.3300 inclusive/11.3302 up to 11.3305 inclusive/11.4036 up to 11.4155 inclusive/ 11.4157/11.4159/11.4164/11.4186 up to 11.4195 inclusive/11.4206 up to 11.4235 inclusive/ 11.4244 up to 11.4246 inclusive/11.4256 up to 11.4265 inclusive/11.4284/11.4306 up to 11.4316 inclusive/11.4318/11.4319/11.4321/11.4322/11.4327/11.4331 up to 11.4335 inclusive/11.4516/ 11.4545/11.4549 up to 11.4552 inclusive/11.4554/11.4555/11.4566 up to 11.4585 inclusive, delivered as spare parts or installed at engine maintenance/general overhaul.

NOTE: Fuel pumps part no. 893114 with the following serial number (S/N) that were installed in the above-mentioned engine and delivered as spare parts are also affected.

S/N 11.3117 up to S/N 11.3325 inclusive
S/N 11.4036 up to S/N 11.4355 inclusive
S/N 11.4516 up to S/N 11.4595 inclusive
S/N 12.0251 up to S/N 12.0270 inclusive

1.2) Concurrent ASB/SB/SI and SL

None

1.3) Reason

Due to variations in the manufacturing of the fuel hose, rubber particles may become detached. These particles can interfere or suppress the fuel mixture in the carburetor. This disturbance in the fuel mixture may lead to rough engine operation, engine misfire and can cause an engine shut down.

d05137.fm

ALERT SERVICE BULLETIN

1.4) Subject

Replacement of the pressure side fuel hose at fuel pump part number 893114 for ROTAX® engine type 912 (Series).

1.5) Compliance

- **Required before the next flight, the “replacement of the pressure side fuel hose“ identified by the engine or fuel pump serial number (S/N) listed in section 1.1) must be conducted according to the following instructions in section 3.**



Non-compliance with these instructions could result in engine damages, personal injuries or even fatal injury.

1.6) Approval

The technical content of this document is approved under the authority of DOA ref.EASA.21J.048.

1.7) Manpower

Estimated man-hours:

Engine installed in the aircraft - - - manpower time will depend on installation and therefore no estimate is available from the engine manufacturer.

1.8) Mass data

Change of weight - - none.

Moment of inertia- - - unaffected.

1.9) Electrical load data

No change

1.10) Software accomplishment summary

No change

1.11) References

In addition to this technical information refer to current issue of

- Illustrated Parts Catalog (IPC)
- Maintenance Manual (MM)

NOTE: The status of Manuals can be determined by checking the table of amendments of the Manual. The 1st column of this table is the revision status. Compare this number to that listed on the ROTAX WebSite: www.FLYROTAX.com. Updates and current revisions can be downloaded for free.

1.12) Other publications affected

None

1.13) Interchangeability of parts

- All used parts and spare parts which cannot be used must be returned F.O.B to a ROTAX® Authorized Distributors or their Service Center.

d05137.fm

ALERT SERVICE BULLETIN

2) Material Information

2.1) Material- cost and availability

Price and availability and any possible support consideration will be supplied on request by ROTAX® Authorized Distributors or their Service Center.

2.2) Company support information

- Redundant parts must be returned F.O.B to a ROTAX® Authorized Distributors or their Service Center.
- Shipping cost, down time, loss of income, telephone costs etc. or cost of conversion to other engine versions or additional work, as for instance simultaneous engine overhaul is not covered in this scope and will not be borne or reimbursed by ROTAX®.

2.3) Material requirement per engine

parts requirement:

Fig. Pos. no.	New part no.	Qty/ engine	Description	Old part no.	Application
2, 9	874336	1	Fuel hose assy.	874335	Fuel pump assy. part no. 893114 (pressure side)
11	250425	1	Gasket ring A10x14	230150	Fuel hose
8	-	3	Gasket ring A8x13/0.8	950143	Clamp block

2.4) Material requirement per spare part

None

2.5) Rework of parts

None

2.6) Special tooling/lubricant-/adhesives-/sealing compound

Price and availability will be supplied on request by ROTAX® Authorized Distributors or their Service Centers.

d05137.fm

ALERT SERVICE BULLETIN

3) Accomplishment / Instructions

NOTE: Before maintenance, review the entire documentation to make sure you have a complete understanding of the procedure and requirements.

Accomplishment

All the measure must be taken and confirmed by at least one of the following person or facilities:

- ROTAX® - Airworthiness representative
- ROTAX® - Distributors or their Service Center
- Persons approved by the respective Aviation Authority

NOTE: All work has to be performed in accordance with the relevant Maintenance Manual.

Safety notice

WARNING

Proceed with this work only in a non-smoking area and not close to sparks or open flames. Switch off ignition and secure engine against unintentional operation. Secure aircraft against unauthorized operation. Disconnect negative terminal of aircraft battery.

WARNING

Risk of scalds and burns! Allow engine to cool sufficiently and use appropriate safety gear while performing work.

NOTICE

Should removal of a locking device (e.g. lock tabs, self-locking fasteners, etc.) be required when undergoing disassembly/assembly, always replace with a new one.

3.1) Inspection of carburetor

General

Several carburetors have been found with contamination (dirt, remains of rubber from fuel lines etc.) in the float chamber.

WARNING

This contamination could possibly cause a partial or complete blockage of the idle or main jet or of other ducts vital for operation, leading to poor performance or stoppage of engine.

3.1.1) Possible shortcomings in the fuel system

- Dirt in the fuel system
- Missing or unsuitable fuel filter
- Clogged fuel filter
- Unsuitable fuel lines
- Dirt in fuel manifold
- Poor float chamber venting
- Insufficient flushing of the fuel system prior to initial engine operation
- Fuel pressure too low or too high
- Unsuitable fuel tanks and tank coatings
- Contaminated float chambers (e.g. corrosion caused by high water content in the fuel)

ALERT SERVICE BULLETIN

3.1.2) Inspection of float chamber

See Fig. 2.

ENVIRONMENT NOTE

Be careful that no fuel enters the sewerage system or the soil. Risk of contamination of drinking water!

The inspection of the float chamber must be performed on both carburetors.

NOTICE

At the following work tasks pay special attention to cleanliness. Contamination, which may be caused during the inspection process, could lead to engine malfunction.

Step	Procedure
1	Remove drip tray (1) - if equipped.
2	Perform visual check on carburetors and its actuation.
3	Open spring clip (2).
4	Remove float chamber (3) including gasket (4) and both floats (5).
5	Check float chamber for contamination.

NOTICE

In case of contaminations of the float chambers first the cause must be found and the relevant measures need to be taken. Possibly the whole fuel system including carburetors needs to be cleaned and checked.

Step	Procedure
6	Install float chamber (3) including gasket (4) and both floats (5).
7	Close spring clip (2).
8	Install drip tray (1) - if equipped.

d05137.fm

ALERT SERVICE BULLETIN

3.2) Replacement of the fuel hose assy. part no. 874335

Safety notice

WARNING

Risks of scalds and burns! Allow engine to cool sufficiently and use appropriate safety gear while performing work.

WARNING

Proceed with this work only in a non-smoking area and not close to sparks or open flames. Switch off ignition and secure engine against unintentional operation. Secure aircraft against unauthorized operation. Disconnect negative terminal of aircraft battery.

3.2.1) Disassembling fuel hose

See Fig. 2.

Step	Procedure
1	Remove banjo bolt (6) from clamp block (7) together with 3 gasket rings (8).
2	Remove the fuel hose (9).
3	Remove the fuel hose (9) from the fuel pump (10) together with gasket ring (11).

ENVIRONMENT NOTE

Be careful that no fuel enters the sewerage system or the soil. Risk of contamination of drinking water!

3.2.2) Checking of the fuel pump

See Fig. 2

Step	Procedure
1	Inspection of the thread (12) from the fuel pump and remove possible sealing materials.
2	Clean and degrease thread (12) of the fuel pump.

3.2.3) Assembling fuel hose assy. part no. 874336

See Fig. 2

Step	Procedure
1	Install the new fuel hose (9) and new gasket ring A 10x14 (11) with LOCTITE 243 on the fuel pump. Tightening torque 10 Nm (90 in.lb).
2	Install fuel hose (9) and the banjo bolt (6) with new gasket ring (8) on the clamp block (7). Tightening torque of banjo bolt (6) 10 Nm (90 in.lb). Check that the fuel hose is not under strain or tension.

- Restore aircraft to original operating configuration.
- Connect negative terminal of aircraft battery.

d05137.fm

ALERT SERVICE BULLETIN

3.3) Test run

Conduct test run including ignition check and leakage test.

3.4) Inspection of float chamber

See chap. 3.1.2).

3.5) Summary

Optionally check the fuel hoses that run from clamp block to tank respectively remove and purge them with fuel

These instructions (section 3) have to be conducted in accordance with compliance in section 1.5. The execution of the mandatory Alert Service Bulletin must be confirmed in the logbook.

Approval of translation to best knowledge and judgement-in any case the original text in German language and the metric units (SI-system) are authoritative.

3.6) Enquiries

Enquiries regarding this Service Letter/Instruction/Bulletin should be referred to the ROTAX® authorized distributor of your area. A list of all distributors is provided on www.FLYROTAX.com.

ALERT SERVICE BULLETIN

4) Appendix

the following illustrations should convey additional information:

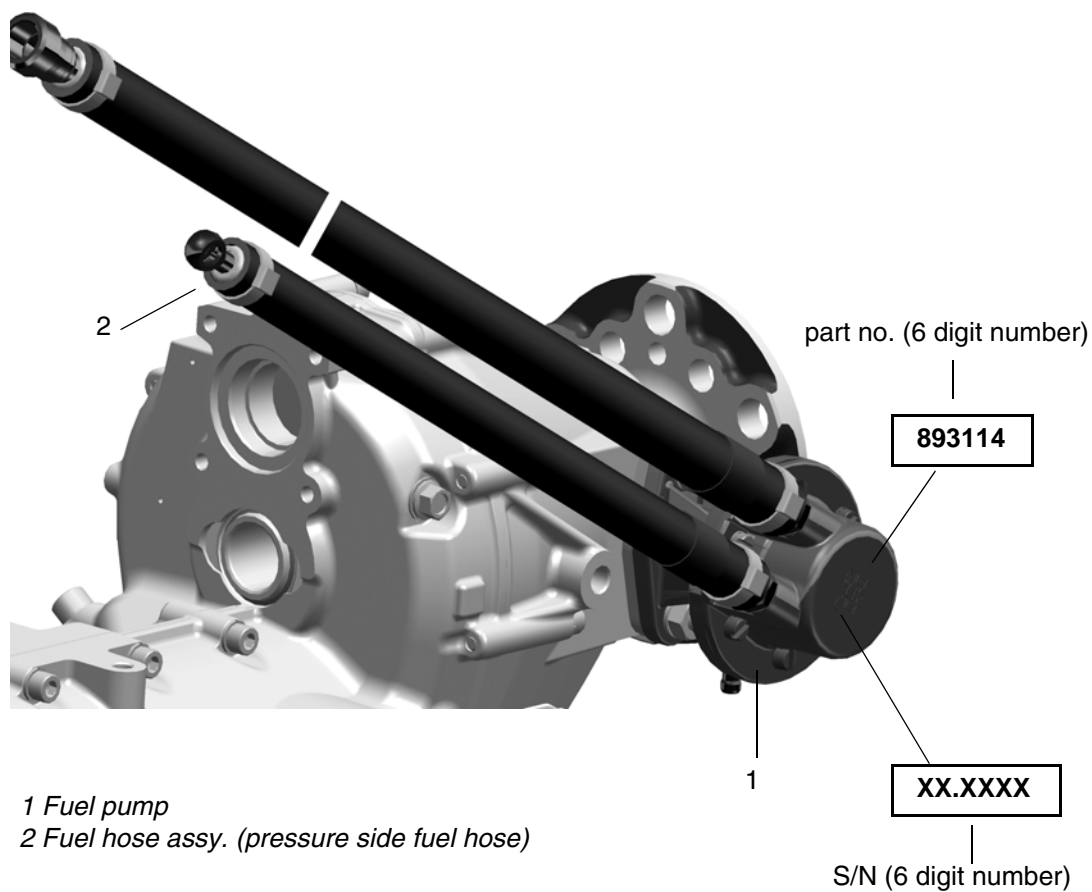
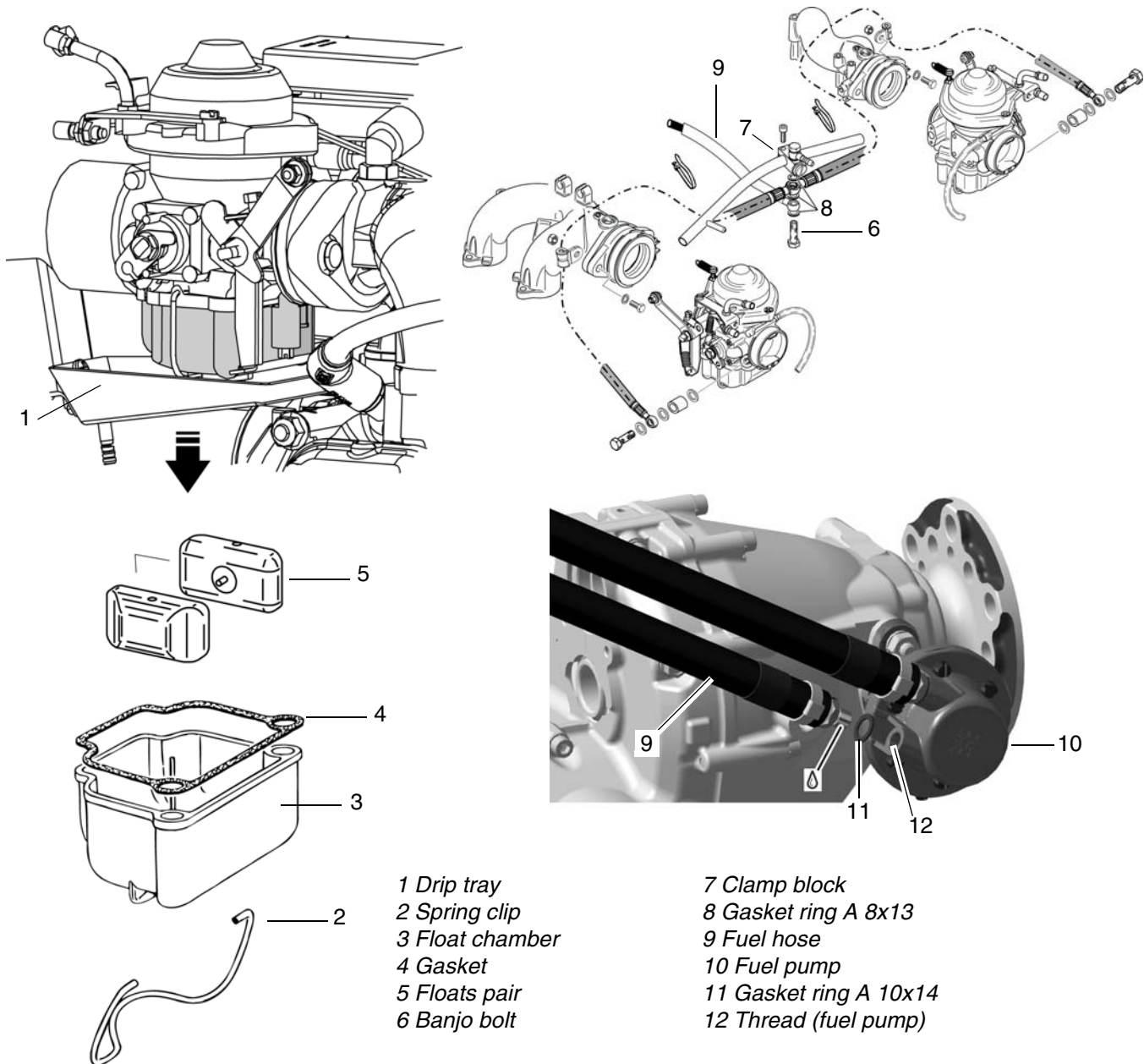

Fig. 1
Fuel pump

09749

d05137.fm

ALERT SERVICE BULLETIN



- 1 Drip tray
- 2 Spring clip
- 3 Float chamber
- 4 Gasket
- 5 Floats pair
- 6 Banjo bolt

- 7 Clamp block
- 8 Gasket ring A 8x13
- 9 Fuel hose
- 10 Fuel pump
- 11 Gasket ring A 10x14
- 12 Thread (fuel pump)

Fig. 2
Carburetor, Fuel pump

09748, 09747, 09745

NOTE:

The illustrations in this document show the typical construction. They may not represent full detail or the exact shape of the parts which have the same or similar function.

Exploded views are **not technical drawings** and are for reference only. For specific detail, refer to the current documents of the respective engine type.

d05137.fm