

SERVICE BULLETIN
CHECKING OR REPLACEMENT
OF FLEXIBLE FUEL LINE
FOR ROTAX® ENGINE TYPE 912 (SERIES)
SB-912-054 UL

MANDATORY

Repeating symbols:

Please, pay attention to the following symbols throughout this document emphasizing particular information.

- ▲ **WARNING:** Identifies an instruction, which if not followed, may cause serious injury or even death.
- **CAUTION:** Denotes an instruction which if not followed, may severely damage the engine or could lead to suspension of warranty.
- ◆ **NOTE:** Information useful for better handling.

1) Planning information

1.1) Engines affected

All versions of the engine type:

- 912 UL from S/N 4,408.199 to S/N 4,408.331
- 912 ULS from S/N 5,647.489 to S/N 5,648.153
- 912 ULSFR from S/N 4,430.445 to S/N 6,374.048

if they are equipped with the genuine ROTAX® flexible fuel lines part no. 874910. In case of doubt contact your aircraft manufacturer.

Also affected are all engines in which flexible fuel line part no. 874910 or retrofit kit part no. 881980 (with the fuel line part no. 874910) were installed at engine repair/general overhaul.

For complete instructions and compliance to this Service Bulletin refer to SB-912-054, latest edition section 1.2 onward.

- ◆ **NOTE:** Section 1.6) Approval: Is not required for engines of the type UL (series).
Section 3) Accomplishment: In addition: persons with adequate type-specific training.

SERVICE BULLETIN

CHECKING OR REPLACEMENT OF FLEXIBLE FUEL LINE FOR ROTAX® ENGINE TYPE 912 (SERIES) SB-912-054

MANDATORY

Repeating symbols:

Please, pay attention to the following symbols throughout this document emphasizing particular information.

▲ **WARNING:** Identifies an instruction, which if not followed, may cause serious injury or even death.

■ **CAUTION:** Denotes an instruction which if not followed, may severely damage the engine or could lead to suspension of warranty.

◆ **NOTE:** Information useful for better handling.

1) Planning information

1.1) Engines affected

All versions of the engine type:

- 912 A from S/N 4,410.713 to S/N 4,410.727
- 912 F from S/N 4,412.923 to S/N 4,412.925
- 912 S from S/N 4,923.384 to S/N 4,923.458

if they are equipped with the genuine ROTAX® flexible fuel lines part no. 874910. In case of doubt contact your aircraft manufacturer.

Also affected are all engines in which flexible fuel line part no. 874910 or retrofit kit part no. 881980 (with the fuel line part no. 874910) were installed at engine repair/general overhaul.

1.2) Concurrent ASB/SB/SI and SL

In addition to this Service Bulletin the following additional Service Instructions must be observed and complied with:

- Service Instructions- SI-25-1997, "Running modifications" current issue.

1.3) Reason

Due to a chemical reaction of the adhesive (in the area of the yellow position marks on the firesleeve) porosity and/or cracks on the firesleeve can occur.

Fuel leakage within this area is not an issue, as only the fireproof protection hose is affected and the fuel is routed in a wire braid reinforced teflon hose.

(see Fig. 3)

1.4) Subject

Checking or replacement of flexible fuel line for ROTAX® engine type 912 series.

1.5) Compliance

- before the first installation
- At the next maintenance, but at the latest by August 1st 2007 the "checking or replacement of flexible fuel line" must be conducted according to the following instructions in section 3.

▲ **WARNING:** Non-compliance with these instructions could result in engine damages, personal injuries or death.

1.6) Approval

The technical content is approved under the authority of DOA Nr. EASA.21J.048.

1.7) Manpower

Estimated man-hours:

engine installed in the aircraft - - - manpower time will depend on installation and therefore no estimate is available from the engine manufacturer.

1.8) Mass data

change of weight - - - none.

moment of inertia - - - unaffected.

1.9) Electrical load data

no change

1.10) Software accomplishment summary

no change

1.11) References

In addition to this technical information refer to current issue of

- Illustrated Parts Catalog (IPC)
- all relevant Service Instructions (SI)
- Maintenance Manual (MM)

◆ NOTE: The status of Manuals can be determined by checking the table of amendments of the Manual. The 1st column of this table is the revision status. Compare this number to that listed on the ROTAX WebSite: www.rotax-aircraft-engines.com. Updates and current revisions can be downloaded for free.

1.12) Other publications affected

none

1.13) Interchangeability of parts

- All parts are interchangeable

2) Material Information

2.1) Material - cost and availability

Price and availability will be supplied on request by ROTAX[®] Authorized Distributors or their Service Center.

2.2) Company support information

- Redundant parts must be returned F.O.B. to a ROTAX[®] Authorized Distributor or Service Center.

2.3) Material requirement per engine

parts requirement:

<u>Fig.no.</u>	<u>New p/n</u>	<u>Qty/engine</u>	<u>Description</u>	<u>Old p/n</u>	<u>Application</u>
	874911	1	fuel line assy.	874910	912
	866716	2	cable ties	866716	fuel line
	950143	3	gasket ring 8.2/13/1.4	950143	clamp block
	950141	3	gasket ring A8x13/0.8	950141	carburetor socket

◆ NOTE: All gasket rings must always be replaced with a new one. Check the different thickness of the gasket rings (pos. 4 and pos. 11).

◆ NOTE: The relevant part number and S/N of the fuel line is attached and/or evident on the metal tag on the hose (see Fig. 4).

2.4) Material requirement per spare part

none

2.5) Rework of parts

none

2.6) Special tooling/lubricant-/adhesives-/sealing compound - Price and availability

none

3) Accomplishment/Instructions

Accomplishment

Incorporation into the respective documentation

All the measures must be taken and confirmed by the following persons or facilities:

- ROTAX[®] -Airworthiness representative
- ROTAX[®] -Distributors or their Service Centers
- Persons approved by the respective Aviation Authority

▲ **WARNING:** Proceed with this work only in a non-smoking area and not close to sparks or open flames. Switch off ignition and secure engine against unintentional operation. Secure aircraft against unauthorized operation. Disconnect negative terminal of aircraft battery.

▲ **WARNING:** Risk of scalds and burns! Allow engine to cool sufficiently and use appropriate safety gear while performing work.

▲ **WARNING:** Should removal of a locking device (e.g. lock tabs, self-locking fasteners, etc.) be required when undergoing disassembly/assembly, always replace with a new one.

◆ **NOTE:** All work has to be performed in accordance with the relevant Maintenance Manual.

3.1) Instructions

(see fig. 1 and 2)

3.1.1) Checking flexible fuel line

Visual inspection of the fuel line (1) in the area clamp (7) and both ends of the yellow protection cover. (see Fig. 1)

◆ **NOTE:** A possible crack can be observed by careful bending of the fuel line. If you notice cracks or porosity then you need to replace the fuel line in accordance section 3.1.2.

3.1.2) Disassembling flexible fuel line

(see Fig. 2)

◆ **NOTE:** See also SI-25-1997 „Running modifications“, current issue.

■ **CAUTION:** When removing fuel lines, support them adequately to avoid strain or additional load.

1. Unscrew the banjo bolt (2) with distance sleeve (3) and 3 gasket rings (4).

2. Cut the cable tie (5).

3. Remove hex. nuts M8 (6) together with clamp (7). Held in place by hex. screw (8).

4. Remove banjo bolt (9) from clamp block (10) together with 3 gasket rings (11).

◆ **NOTE:** The gasket rings 8x13 (4), used on the banjo bolt of the carburetor, are of different thickness compared to the gasket rings (11), used on the banjo bolt of the clamp block.

5. Remove the fuel line (12).

3.1.3) Assembling flexible fuel line

1. Install flexible fuel line (1 and 12) and the banjo bolt (9) with new sealing ring (11) on the clamp block (10). Tightening torque of banjo bolt (9) 10 Nm (90 in.lb). Check that the fuel lines are not under strain or tension.

2. Install both cable clamp (7) in accordance with Fig.1 on the fuel line.

3. Install the fuel line (1) with distance sleeve (3) and sealing ring (4) on the carburetors. Tightening torque of banjo bolt (2) 10 Nm (90 in.lb). Place cable clamp (7) into position.

4. For proper support. Install the clamp (7) and hex. nut M8 (6) with LOCTITE 221. Tightening torque of hex. nut (6) 15 Nm (133 in.lb).

◆ **NOTE:** Hold the hex. screw (8) when tightening hex. nut (6).

5. Fix the fuel line at the compensation tube with 2 cable ties (5).

- Restore aircraft to original operating configuration.
- Connect negative terminal of aircraft battery.

3.2) Test run

Conduct test run including ignition check and leakage test in accordance with the current Maintenance Manual of the respective engine type.

3.3) Summary

These instructions (section 3) have to be conducted in accordance with compliance in section 1.5. The execution of the mandatory Service Bulletin must be confirmed in the logbook.

Approval of translation to best knowledge and judgement - in any case the original text in German language and the metric units (SI-system) are authoritative.

4) Appendix

the following drawings should convey additional information:

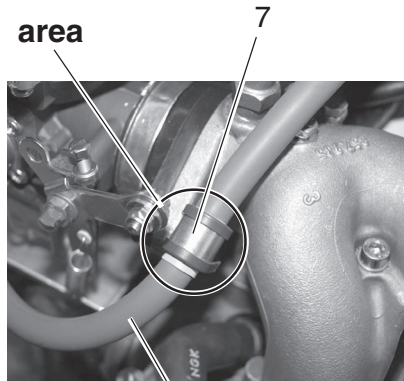
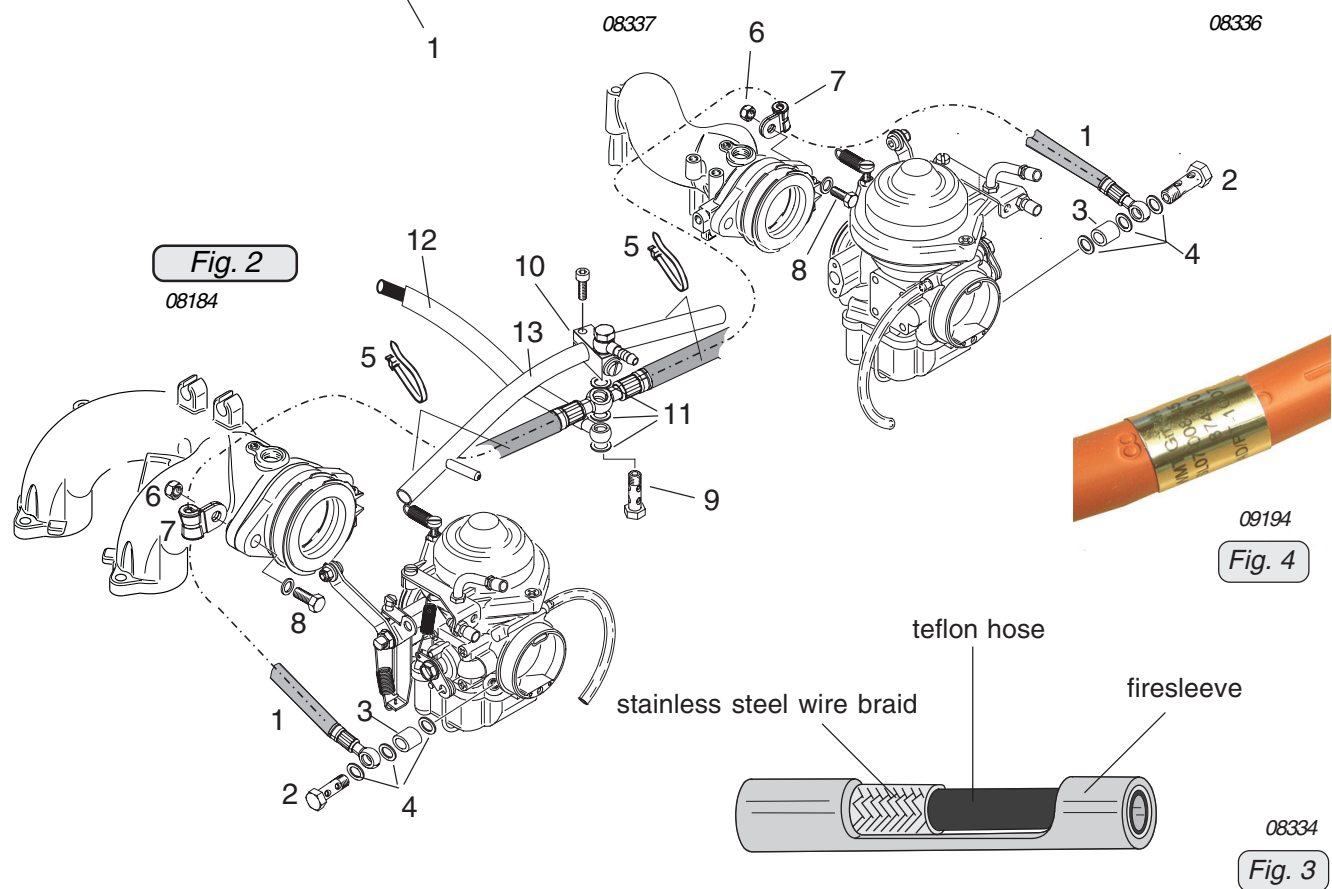
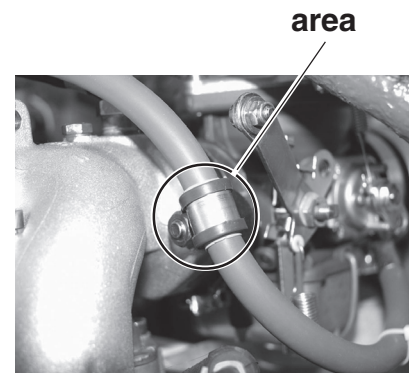

Fig. 1



◆ NOTE: The illustrations in this document show the typical construction. They may not represent full detail or the exact shape of the parts which have the same or similar function. Exploded views are **no technical** drawings and are for reference only. For specific detail, refer to the current documents of the respective engine type.