



# SERVICE BULLETIN

## REPLACEMENT OF PIN PART NO. 929700 IN CARBURETOR FOR ROTAX® ENGINE TYPE 912/914 (SERIES) SB-912-048UL SB-914-033UL

### **MANDATORY**

#### Repeating symbols:

Please, pay attention to the following symbols throughout this document emphasizing particular information.

- ▲ **WARNING:** Identifies an instruction, which if not followed, may cause serious injury or even death.
- **CAUTION:** Denotes an instruction which if not followed, may severely damage the engine or could lead to suspension of warranty.
- ◆ **NOTE:** Information useful for better handling.

#### 1) Planning information

##### 1.1) Engines affected

All versions of the engine type:

- 912 UL from S/N 4,406.417 to S/N 4,407.377
- 912 ULS from S/N 5,643.752 to S/N 5,645.438
- 912 ULSFR from S/N 4,429.981 to S/N 4,430.213
- 914 UL from S/N 4,418.686 to S/N 4,419.132

Following engines are already checked by the manufacturer and therefore not affected from this Service Bulletin:

- 912 ULS 5,645.380 / 5,645.429 to 5,645.436
- 914 UL 4,419.103 to 4,419.107 / 4,419.119 / 4,419.126 / 4,419.127 / 4,419.128 / 4,419.130 / 4,419.134 / 4,419.135
- all CD-carburetors from S/N 04.2017 to S/N 05.3400, delivered as spare part until September 07, 2005.
- Also affected, are all engines equipped with pin part no. 929700 as a spare part in a CD-carburetor, installed from June 24 2004 to September 07 2005.

For complete instructions and compliance to this Service Bulletin refer to Service Bulletin -SB-912-048, SB-914-033, latest edition section 1.2 onward.

- ◆ **NOTE:** Section 1.6) Approval: Is not required for engines of the type UL (series).  
Section 3) Accomplishment: In addition: persons with adequate type-specific training.

d03457



AIRCRAFT ENGINES

# SERVICE BULLETIN

## REPLACEMENT OF PIN PART NO. 929700 IN CARBURETOR FOR ROTAX® ENGINE TYPE 912/914 (SERIES) SB-912-048 SB-914-033

### **MANDATORY**

#### Repeating symbols:

Please, pay attention to the following symbols throughout this document emphasizing particular information.

▲ **WARNING:** Identifies an instruction, which if not followed, may cause serious injury or even death.

■ **CAUTION:** Denotes an instruction which if not followed, may severely damage the engine or could lead to suspension of warranty.

◆ **NOTE:** Information useful for better handling.

#### 1) Planning information

##### 1.1) Engines affected

All versions of the engine type:

- 912 A from S/N 4,410.634 to S/N 4,410.666
- 912 F from S/N 4,412.875 to S/N 4,412.905
- 912 S from S/N 4,923.067 to S/N 4,923.221
- 914 F from S/N 4,420.428 to S/N 4,420.502

- all CD-carburetors from S/N 04.2017 to S/N 05.3400, delivered as spare part until September 07. 2005.

- Also affected, are all engines equipped with pin part no. 929700 as a spare part in a CD-carburetor, installed from June 24 2004 to September 07 2005.

##### 1.2) Concurrent ASB/SB/SI and SL

none

##### 1.3) Reason

In limited cases a production deviation of the pin in the carburetor may lead to flaking of the surface coating and may cause contamination in the float chamber.

▲ **WARNING:** Contamination in the fuel system may cause engine failure and/or performance drop.

##### 1.4) Subject

Replacement of pin part no. 929700 in carburetor for ROTAX® Engine Type 912/914 (Series)

##### 1.5) Compliance

- Engines/spare parts not yet delivered before delivery.
- Before first installation of engine/spare part.
- Before next flight at signs of abnormal engine run.
- During the next maintenance event, but within next 25 hours of operation, but in any event no later then on December 1, 2005,

the pin shall be replaced as per the following instructions section 3.

▲ **WARNING:** Non-compliance with these instructions could result in engine damages, personal injuries or death.

##### 1.6) Approval

The technical content is approved under the authority of DOA Nr. EASA.21J.048.

d03455

### 1.7) Manpower

Estimated man-hours:

Engine installed in the aircraft - - -manpower time will depend on installation and thus, no estimate is available from the engine manufacturer.

### 1.8) Mass data

Change of weight - - - none.

Moment of inertia - - - unaffected.

### 1.9) Electrical load data

No change

### 1.10) Software accomplishment summary

No change

### 1.11) References

In addition to this technical information refer to current issue of

- Maintenance Manual (MM)

- Illustrated Parts Catalog (IPC)

### 1.12) Other publications affected

none

### 1.13) Interchangeability of parts

- All used parts which cannot be used must be returned F.O.B. to a ROTAX<sup>®</sup> Authorized Distributors or Service Centers.

## 2) Material Information

### 2.1) Material - cost and availability

Price and availability will be supplied on request by ROTAX<sup>®</sup> Authorized Distributors or their Service Centers.

### 2.2) Company support information

None

### 2.3) Material requirement per engine

parts requirement:

Fig.no.	New part no.	Qty/engine	Description	Old part no.	Application
	929701	2	pin	929700	carburetor
	-	as required	gasket	830727	carburetor
	-	as required	o-ring 15.5x7.8	631770	carburetor 914 (series)

### 2.4) Material requirement per spare part

parts requirement:

Fig.no.	New part no.	Qty/engine	Description	Old part no.	Application
	929701	1	pin	929700	carburetor
	-	as required	gasket	830727	carburetor
	-	as required	o-ring 15.5x7.8	631770	carburetor 914 (series)

### 2.5) Rework of parts

None

### 2.6) Special tooling/lubricant-/adhesives-/sealing compound - Price and availability

Parts requirement:

Fig.no.	part no.	Qty/engine	Description	Old part no.	Application
	-	1	pin punch 2mm(.079 in.)	-	float bracket

### 3) Accomplishment / Instructions

#### Accomplishment

All the measures must be taken and confirmed by the following persons or facilities:

- ROTAX<sup>®</sup> -Airworthiness representative
- ROTAX<sup>®</sup> -Distributors or their Service Centers
- Persons approved by the respective Aviation Authority

▲ **WARNING:** Proceed with this work only in a non-smoking area and not close to sparks or open flames. Switch off ignition and secure engine against unintentional operation. Secure aircraft against unauthorized operation. Disconnect negative terminal of aircraft battery.

▲ **WARNING:** Risk of scalds and burns! Allow engine to cool sufficiently and use appropriate safety gear while performing work.

▲ **WARNING:** Should removal of a locking device (namely lock tabs, self-locking fasteners) be required when undergoing disassembly/assembly, always replace with a new one.

#### 3.1) General

(see fig. 1-3)

#### 3.2) Replacement of the pin part no. 929700

■ **CAUTION:** All work has to be performed in accordance with the relevant Maintenance Manual.

- Disconnect negative terminal of aircraft battery.
- Remove drip tray - if equipped.
- Remove carburetor.
- Open spring clip (1) or ROTAX<sup>®</sup> 914 (Series) open attachment screw (2) with o-ring (3).
- Remove float chamber (4) with gasket (5) and float (6).
- Remove pin (7) with appropriate pin punch (8) and remove float bracket (9) with float needle clip (10) and float needle valve (11)

◆ **NOTE:** The pin is serrated on one side (12). Put the pin punch on the opposite side and press out the pin. Don't damage the carb casting by pressing the serrated end through the pin support.

- Inspect the pin for flaking (13) of surface coating.
- Clean carburetor and fuel system, especially in case of flaking on the pin
- Check parts of carburetor.
- Install float bracket with float needle clip/float needle valve and the new pin part no. 929701
- Check if float suspension brackets are parallel and adjust if necessary.
- Install float chamber with gasket and float.
- Reassemble the carburetor.
- Install carburetor.
- Install drip tray - if equipped.
- Connect negative terminal of aircraft battery.
- perform basic throttle adjustment

#### 3.3) Test run

Start engine. Perform carburetor synchronisation. Conduct test run including ignition check and leakage test in accordance with the relevant Maintenance Manual.

#### 3.4) Summary

These instructions (section 3) have to be conducted in compliance with section 1.5.

The execution of the mandatory Service Bulletin must be confirmed in the logbook.

Approval of translation to best knowledge and judgment - in any case the original text in the German language and the metric units (SI-system) are authoritative.

#### 4) Appendix

The following drawings should provide additional information:

- 1 spring clip
- 2 attachment screw assy.
- 3 O-Ring
- 4 float chamber
- 5 gasket
- 6 float
- 7 pin
- 8 pin punch
- 9 float bracket
- 10 float needle clip
- 11 float needle valve
- 12 serrated end
- 13 flaking

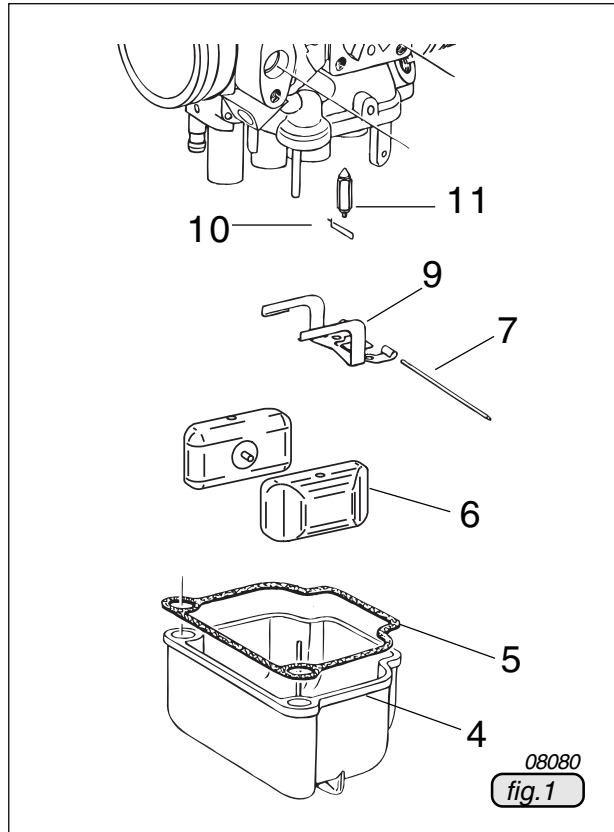

engine  
912/914

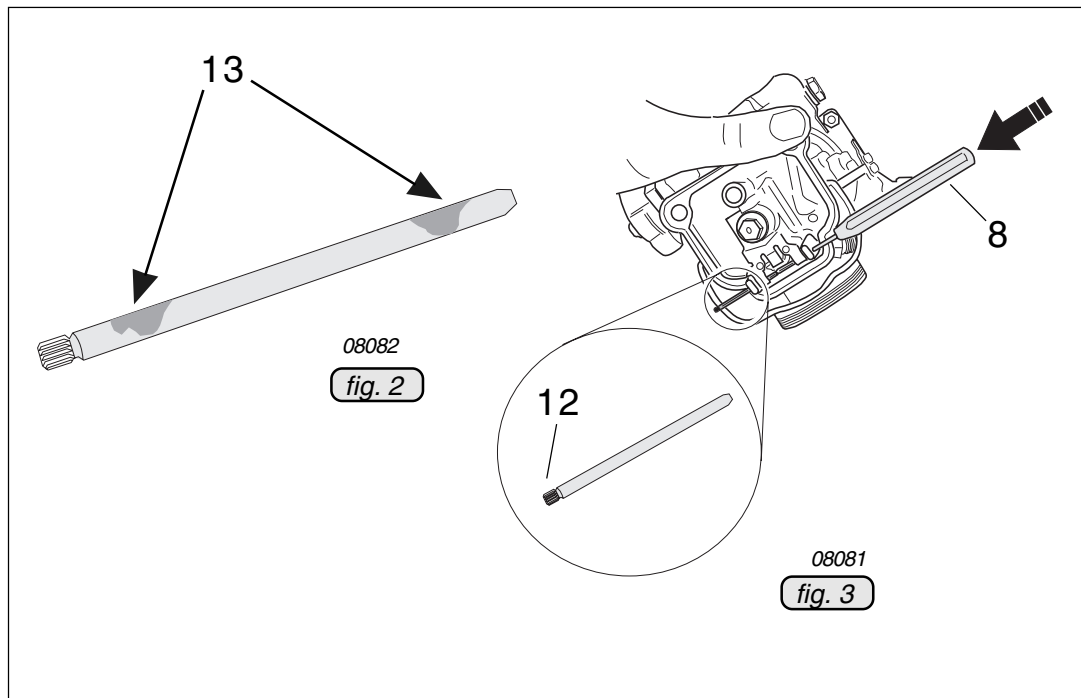
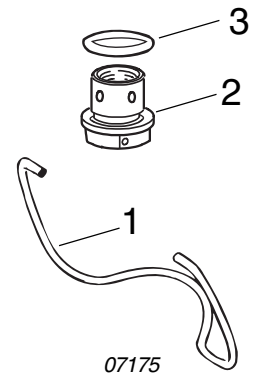

- ◆ NOTE: The illustrations in this document show the typical construction. They may not represent full detail or the exact shape of the parts which have the same or similar function.  
Exploded views are **not technical** drawings and are for reference only. For specific detail, refer to the current documents of the respective engine type.