



# SERVICE BULLETIN

## CHECK OF ALLEN SCREW M8X100 IN THE CRANKCASE ON ROTAX® ENGINE TYPE 912/914 SB-912-047UL SB-914-032UL

### **MANDATORY**

#### Repeating symbols:

Please, pay attention to the following symbols throughout this document emphasizing particular information.

- ▲ **WARNING:** Identifies an instruction, which if not followed, may cause serious injury or even death.
- **CAUTION:** Denotes an instruction which if not followed, may severely damage the engine or could lead to suspension of warranty.
- ◆ **NOTE:** Information useful for better handling.

#### 1) Planning information

##### 1.1) Engines affected

All versions of the engine type:

- 912 UL from S/N 4,407.247 to S/N 4,407.339
- 912 ULS from S/N 5,645.088 to S/N 5,645.350
- 912 ULSFR from S/N 4,430.141 to S/N 4,430.150
- 914 UL from S/N 4,419.052 to S/N 4,419.079

Following engines are already checked by the manufacturer and therefore not affected from this Service Bulletin:

- 912 UL: 4,407.267 / 4,407.279 to 4,407.289 / 4,407.296 to 4,407.326 / 4,407.329 to 4,407.335
- 912 ULS: 5,645.184 / 5,645.230 / 5,645.231 / 5,645.233 to 5,645.257 / 5,645.268 to 5,645.274 / 5,645.279 to 5,645.315 / 5,645.317 to 5,645.346
- 914 UL: 4,419.068 / 4,419.069

For complete instructions and compliance to this service bulletin refer to Service Bulletin SB-912-047/ SB-914-032, latest edition section 1.2 onward.

- ◆ **NOTE:** Section 1.6) Approval: Is not required for engines of the type UL (series).  
Section 3) Accomplishment: In addition: persons with adequate type-specific training.

# SERVICE BULLETIN

## CHECK OF ALLEN SCREW M8X100 IN THE CRANKCASE ON ROTAX® ENGINE TYPE 912/914 SB-912-047 SB-914-032

### MANDATORY

#### Repeating symbols:

Please, pay attention to the following symbols throughout this document emphasizing particular information.

- ▲ **WARNING:** Identifies an instruction, which if not followed, may cause serious injury or even death.
- **CAUTION:** Denotes an instruction which if not followed, may severely damage the engine or could lead to suspension of warranty.
- ◆ **NOTE:** Information useful for better handling.

#### 1) Planning information

##### 1.1) Engines affected

All versions of the engine type:

- 912 A                   not affected
- 912 F                   not affected
- 912 S                   from S/N 4,923.183 to S/N 4,923.194
- 914 F                   from S/N 4,420.476 to S/N 4,420.480

Following engines are already checked by the manufacturer and therefore not affected from this Service Bulletin:

- 912 S                   4,923.187 / 4,923.188 / 4,923.192 / 4,923.193

##### 1.2) Concurrent ASB/SB/SI and SL

In addition to this Service Bulletin the following Service Bulletin must be observed and complied with:

- SB-912-037 / SB-914-023 "Installation of an electric starter with enhanced power" current issue.

##### 1.3) Reason

In limited number of cases a deviation in the production of the allen screw may result in cracking of screw head and possible loss of the screw head.

##### 1.4) Subject

Check of allen screw M8X100 part no. 440427 in the crankcase on ROTAX® engine type 912/914.

##### 1.5) Compliance

- Engines not yet delivered must be checked before delivery.
- Before first installation of engine.
- At the first 25 hour inspection
- Within the next 10 hours of operation if TSN is greater than 25 hours.
- No later than October 1<sup>st</sup>, 2005.

▲ **WARNING:** Non-compliance with these instructions could result in engine damages, personal injuries or death.

##### 1.6) Approval

The technical content is approved under the authority of DOA Nr. EASA.21J.048.

d03450

**1.7) Manpower**

Estimated man-hours:

Engine installed in the aircraft - manpower time will depend on installation and thus, no estimate is available from the engine manufacturer.

**1.8) Mass data**

Change of weight - - - none

Moment of inertia - - - unaffected

**1.9) Electrical load data**

no change

**1.10) Software accomplishment summary**

no change

**1.11) References**

In addition to this technical information refer to current issue of  
- Maintenance Manual (MM) of relevant engine type

**1.12) Other publications affected**

none

**1.13) Interchangeability of parts**

All used parts become unusable and must be returned F.O.B. to a ROTAX<sup>®</sup> Authorized Distributors or their Service Centers.

**2) Material Information**

**2.1) Material - cost and availability**

Price and availability will be supplied on request by ROTAX<sup>®</sup> Authorized Distributors or their Service Centers.

**2.2) Company support information**

none

**2.3) Material requirement per engine**

parts requirement:

Fig. no.	New part no.	Qty./ engine	Description	Old part no.	Application
	440427	2	allen screw M8X100		crankcase
	945752	2	lock washer A8		crankcase

**2.4) Material requirement per spare part**

none

**2.5) Rework of parts**

none

**2.6) Special tooling/lubricant-/adhesives-/sealing compound - Price and availability**

none

Approval of translation to best knowledge and judgment - in any case the original text in the German language and the metric units (SI-system) are authoritative.

### 3) Accomplishment / Instructions

#### Accomplishment

All the measures must be taken and confirmed by the following persons or facilities:

- ROTAX<sup>®</sup> -Airworthiness representative
- ROTAX<sup>®</sup> -Distributors or their Service Centers
- Persons approved by the respective Aviation Authority

▲ **WARNING:** Proceed with this work only in a non-smoking area and not close to sparks or open flames. Switch off ignition and secure engine against unintentional operation. Secure aircraft against unauthorized operation. Disconnect negative terminal of aircraft battery.

▲ **WARNING:** Risk of scalds and burns! Allow engine to cool sufficiently and use appropriate safety gear while performing work.

▲ **WARNING:** Should removal of a locking device (namely lock tabs, self-locking fasteners) be required when undergoing disassembly/assembly, always replace with a new one.

#### 3.1) General

(see fig. 1 and 2)

Only the 2 allen screws M8X100 (1) part no. 440427 are affected by the production deviation. They are installed in the crankcase on the cylinder side 1/3 between cylinder 3 and the electric starter.

Furthermore, only allen screws marked „TMS“ on the screw head are affected.

#### 3.2) Check of allen screw M8X100

(see fig. 1 and 2)

■ **CAUTION:** All work has to be performed in accordance with the relevant Maintenance Manual.

- Disconnect negative terminal of aircraft battery.
- Carefully check the markings on the allen screw head.

◆ **NOTE:** In addition to the quality marking 10.9 (3) the production code must be identified on the screw head. Allen screws with a production code of „TMS“ (4) may be affected and must be replaced in all cases.

■ **CAUTION:** In case of doubt e.g. illegibility of marking the screw has to be replaced.

◆ **NOTE:** Use an appropriate source of light for better visibility.

- Replace affected allen screw (1) including lock washer (2). Tightening torque 30 Nm (265 in.lb.).

■ **CAUTION:** If both allen screws are affected and must be replaced, allen screws and lock washers must be replaced one at a time. Remove and replace the first allen screw and lock washer before loosening or removing the second screw. After the first screw and lock washer has been replaced, remove the second allen screw and install a new allen screw and lock washer.

◆ **NOTE:** If a HD-starter (electric starter with enhanced power) is in use, the starter has to be loosened and slid slightly back before a disassembly of the affected screw is possible.

- Reinstall the HD-starter and check for tight fit.
- Connect negative terminal of aircraft battery.

#### 3.4) Replacement of allen screw M8X100 with cracked head

If an allen screw with a cracked head is discovered, the following steps must be performed:

- Disconnect negative terminal of aircraft battery.
- If a screw head is already cracked, the screw has to be removed with special devices. If a removal should not be possible or additional damage should be found, then the engine must be returned to a ROTAX<sup>®</sup> Authorized Distributors or their Service Centers for repair/overhaul.
- Install new screws in compliance with section 3.2.
- Check „Tight movement of engine“ in accordance with the relevant Maintenance Manual. This check is necessary in order to detect possible damage on the main bearing due to the temporary loss of pre-tension.
- Connect negative terminal of aircraft battery.

#### 3.4) Test run

Start the engine. Conduct test run including ignition check and leakage test according relevant Maintenance Manual.

### 3.5) Summary

These instructions (section 3) have to be conducted in compliance with section 1.5.  
The execution of the mandatory Service Bulletin must be confirmed in the logbook.

### 4) Appendix

The following drawings should provide additional information:

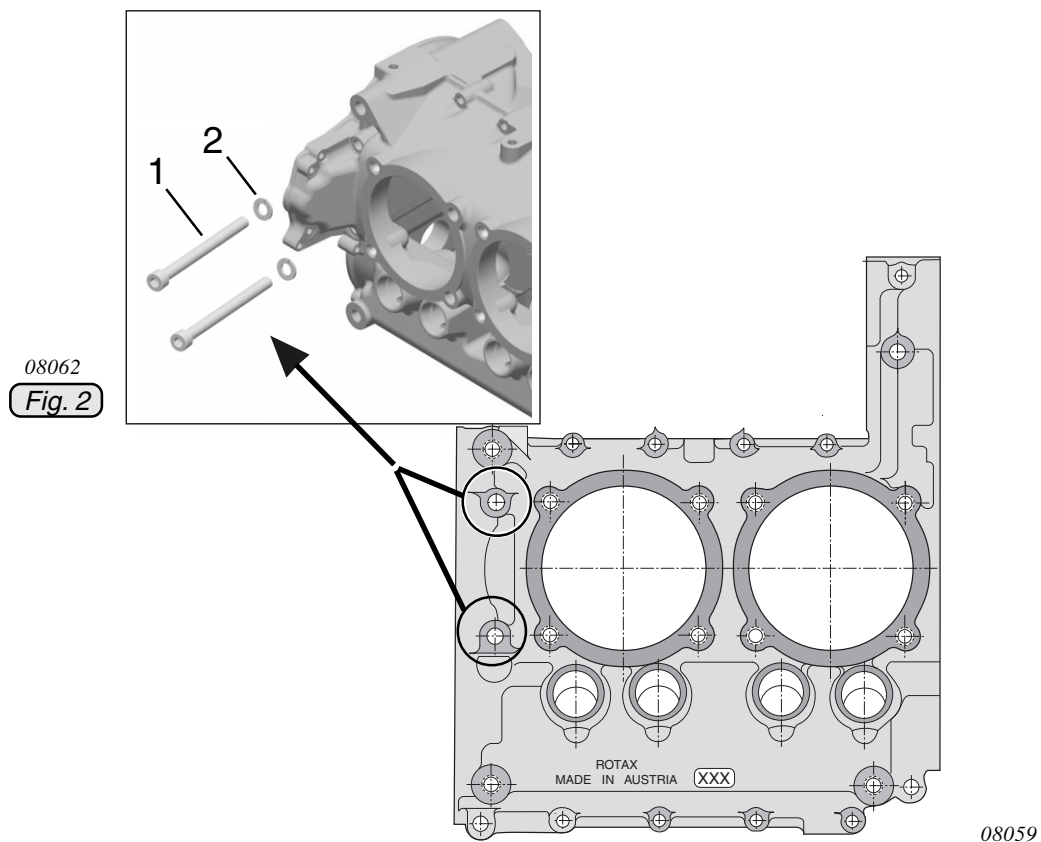
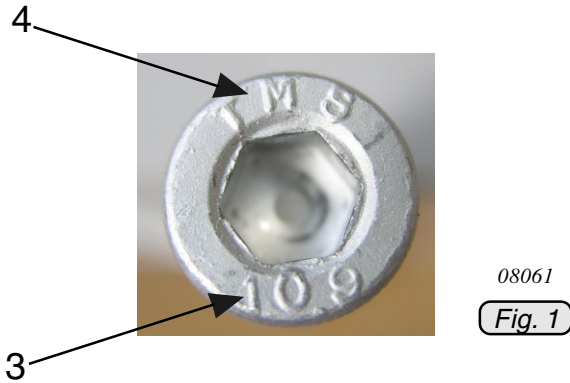

◆ **NOTE:** The illustrations in this document show the typical construction. They may not represent full detail or the exact shape of the parts which have the same or similar function.  
Exploded views are **not technical** drawings and are for reference only. For specific detail, refer to the current documents of the respective engine type.